

LIST OF CONTENTS FICHE III

	Fiche
COPPER ALLOY OBJECTS (FIGS.92-113) by ALISON R. GOODALL; SPUR by BLANCHE ELLIS.	A3
LEAD AND LEAD ALLOY OBJECTS (FIGS.114-18) by GEOFF EGAN (NOS.1-24) AND ALISON R. GOODALL (NOS.25-28).	B13
IRON OBJECTS (FIGS.119-46) by IAN H. GOODALL; SPUR by BLANCHE ELLIS.	C6
SLAG FROM 31-34 CHURCH STREET by C.J. SALTER.	E8
BONE, IVORY AND ANTLER OBJECTS (FIGS.147-67) by GEOFF EGAN (NOS.1-65) AND MARTIN HENIG (NOS.66-70); MATERIAL IDENTIFICATION by PHILIP ARMITAGE AND BOB WILSON.	F1

Photocopies of the microfiche can be obtained from the
Oxford Archaeological Unit, 46 Hythe Bridge Street, Oxford, OX1 2EP.

COPPER ALLOY OBJECTS by ALISON R. GOODALL; SPUR by BLANCHE ELLIS

Figs.92-113

Site A: 1-133; Site B: 134-148; Site D: 149-51; Site SEL: 152-154.

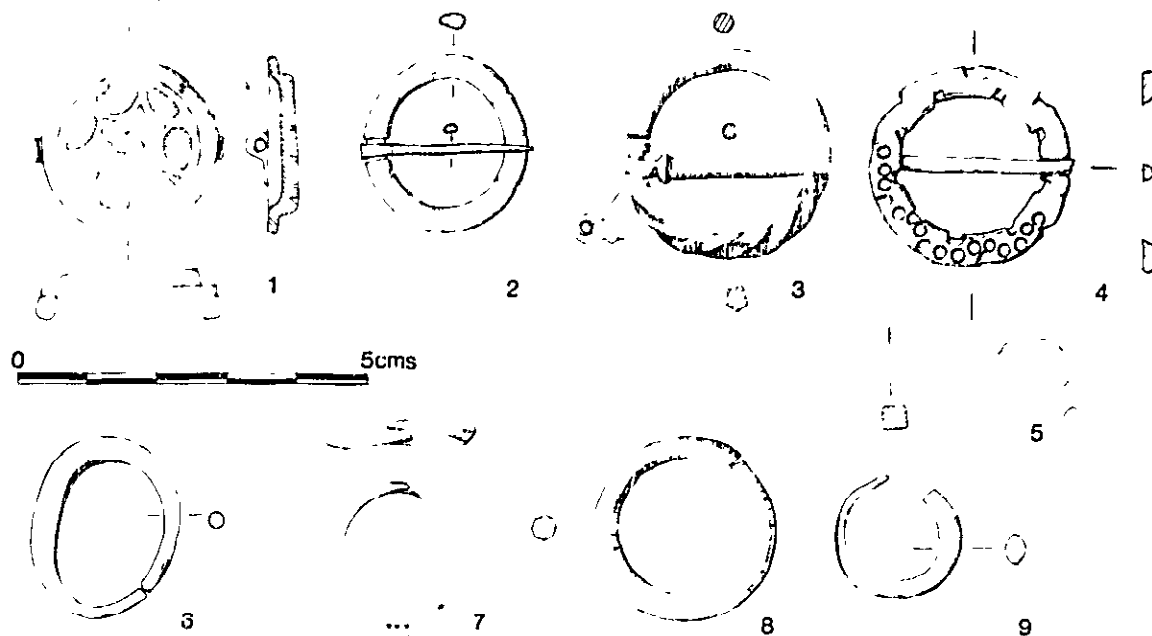

Site A, 31-34 Church St.

Fig.92

1. Disc brooch decorated with champlevé enamel. Hinge and catch-plate on the back.
75.25.1 A SF1153A, F1024 L1231, 13th-cent. context.
- 2-4. Annular brooches. No.2 has a lobed frame and No.3 has twisted decoration on half of the frame. The frame of No.4 is decorated with stamped circles and has notched edges.
2. 75.25.2 A SF206, L2 (2M, 110/1008), unstratified;
3. 75.25.3 A SF1019, L2 (2M, 108/1008), unstratified;
4. 75.25.4 A SF2043, F16 L14, undated context.
5. Brooch pin with moulding below the hinge.
75.25.5 A SF219, L1, undated context.
- 6-9. Penannular ear- or finger-rings with tapering ends. No.8 has longitudinal facets.
6. 75.25.6 A SF1178, F1520 L1, 11th-cent. context;
7. 75.25.7 A SF117, F53 L53, 15th-cent. context;
8. 75.25.8 A SF1170, F1513 L3, undated context;
9. 75.25.9 A SF2085, L2 (2M, 102/1012), unstratified.

COPPER ALLOY OBJECTS

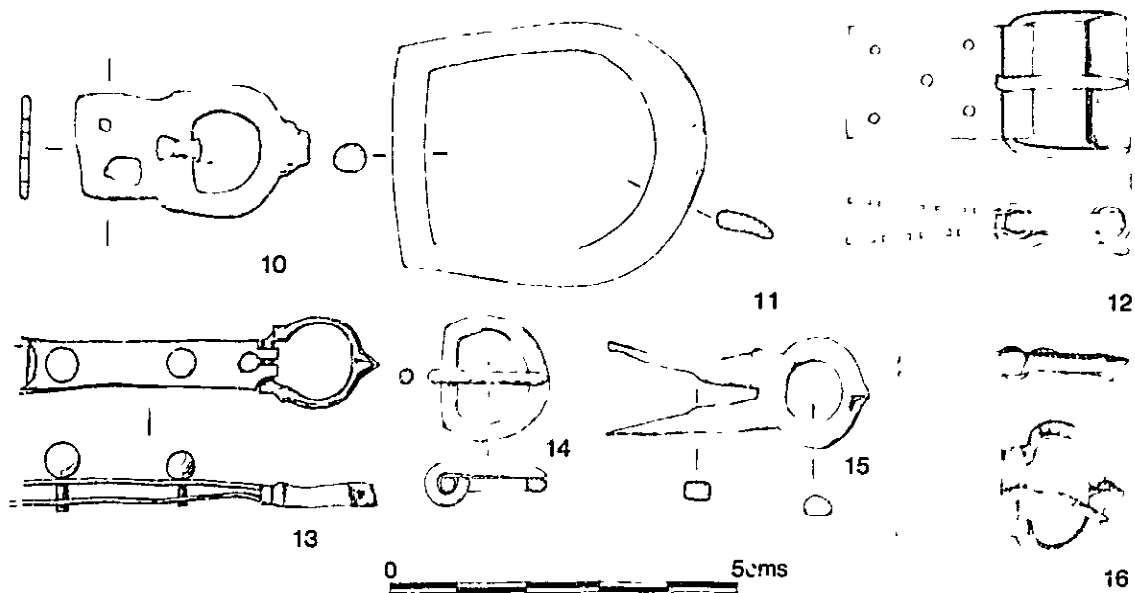

Fig.93

10-24. Buckles. No.10 has an integral strap end with a perforation to take the iron pin and two rivet holes for attachment to the strap. No.11 is a heavy D-shaped buckle and No.12 has a swivelling cylinder on the frame. The buckle plate of No.13 is slender and has two globular headed rivets. Nos.15-18 all have fork-like extensions on to which the plates are soldered. No.19 has a composite frame with a tab swivelling on an iron pin at the front; a small rectangular plate has been soldered on to the tab. This arrangement would have secured a belt, probably of fabric rather than leather, without the need of a buckle pin. No.20, is decorated with stamped circles. No.21 has a hexagonal-sectioned frame. No.22 resembles a buckle frame and may be a faulty casting. No.23 is a belt slide with internally projecting lugs. No. 24 may be a buckle with a moulded projection on the frame.

COPPER ALLOY OBJECTS

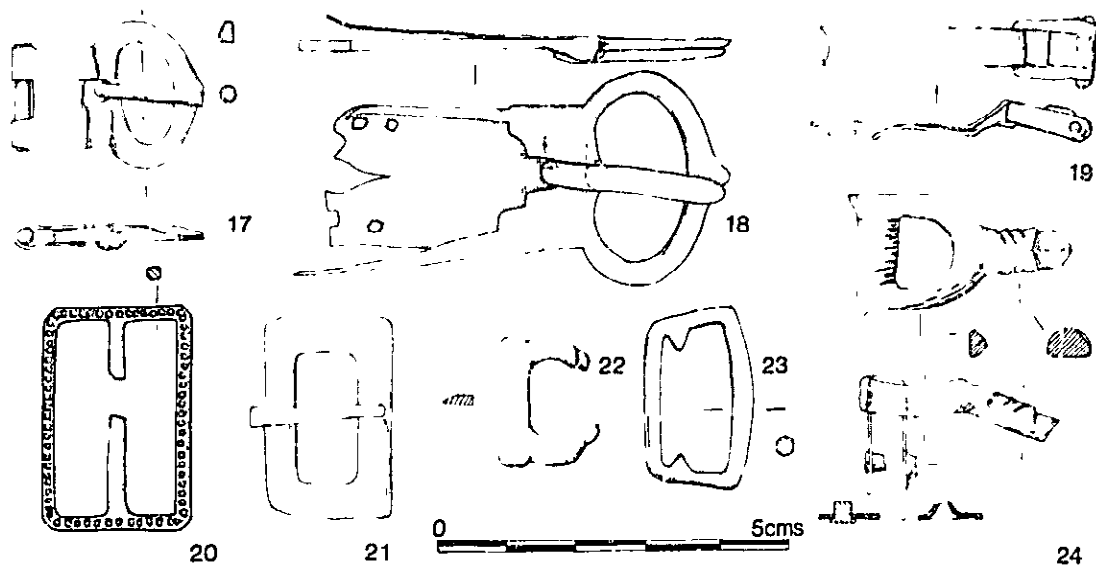

Fig.94

- 10. 75.25.10 A SF2140, L2 (2M, 102/1000), unstratified;
- 11. 75.25.11 A SF540, F119 L219, 11th-cent. context (the buckle is intrusive);
- 12. 75.25.12 A SF1040, F1015 L1093, 14th-cent. context;
- 13. 75.25.13 A SF535, F121 L235, 14th-cent. context;
- 14. 75.25.14 A SF60, F71 L44, early 17th-cent. context;
- 15. 75.25.15 A SF2131, L2531 L1, 16th-cent. context;
- 16. 75.25.16 A SF115, L2 (0.5M, 117.5/1004.5), unstratified;
- 17. 75.25.17 A SF1079, L2 (2M, 110/994), unstratified;
- 18. 75.25.18 A SF1081, L2 (2M, 108/1000), unstratified;
- 19. 75.25.19 A SF1016, F14 L1065, early 17th-cent. context;
- 20. 75.25.20 A SF2040, L2013, undated context;
- 21. 75.25.21 A SF2138, L2013, undated context;
- 22. 75.25.22 A SF1017, L2 (2M, 110/1010), unstratified;
- 23. 75.25.23 A SF213, L2 (2M, 114/1008), unstratified;
- 24. 75.25.32 A SF1167, F1525 L3, 14th-cent. context.

COPPER ALLOY OBJECTS

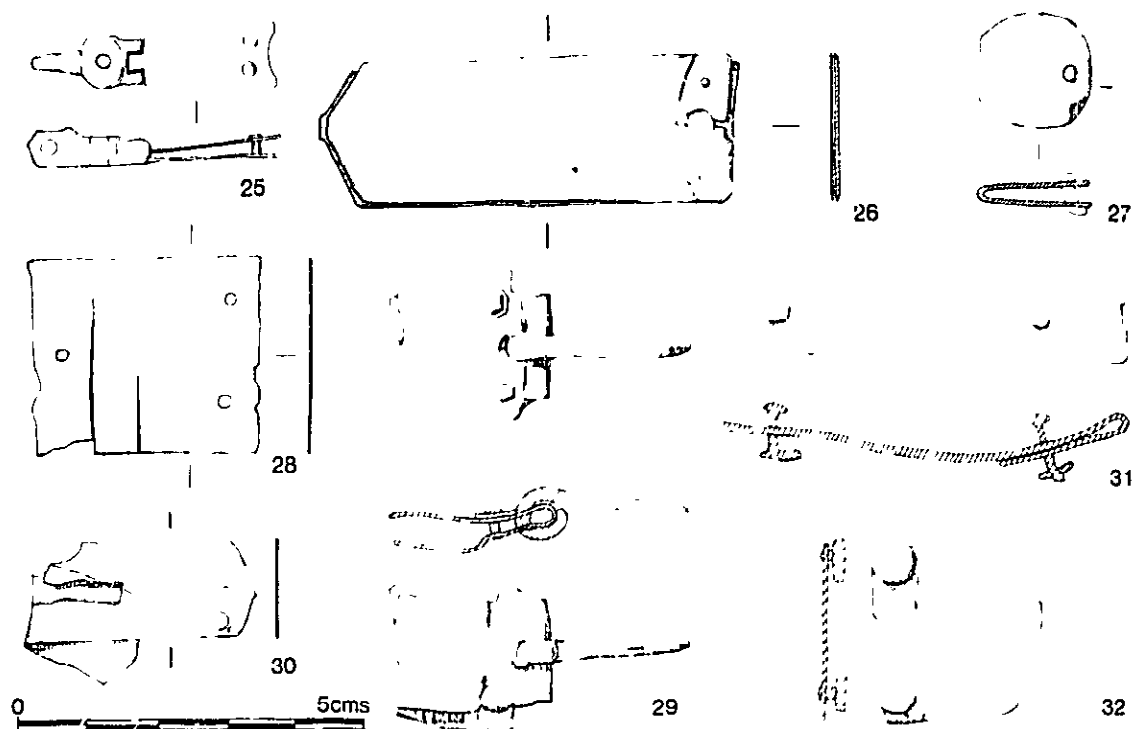

Fig.95

- 25-32. Strap ends and buckle plates. No.25 has a hinged and looped terminal which probably formed part of a book clasp. No.26 consists of a pair of plates which may originally have had a forked spacer between them; the outer plate has incised decoration. No.27 is a plain folded strap end which has been cut to a rounded shape. No.28 has been cut down and cut into and is probably scrap. No.29 retains the pin of the buckle and has a small extra plate on its upper surface which may be a repair. The dome-headed rivets of No.31 pass through washers at the back. The incomplete plate, No.32, has possible traces of gilding.
- | | | |
|-----|----------|---|
| 25. | 75.25.24 | A SF563, F116, 13th-cent. context; |
| 26. | 75.25.25 | A SF215, L2 (2M, 110/1000), unstratified; |
| 27. | 75.25.26 | A SF1046, L2 (2M, 110/1000), unstratified; |
| 28. | 75.25.27 | A SF2160, F2502 L1, 14th-cent. context; |
| 29. | 75.25.28 | A SF12, L2 (2M, 106/1014), unstratified; |
| 30. | 75.25.29 | A SF3067 L1279 (= L2), unstratified; |
| 31. | 75.25.30 | A SF5A, Trial Trench, L17, undated context; |
| 32. | 75.25.31 | A SF34, L2 (2M, 118/994), unstratified. |

COPPER ALLOY OBJECTS

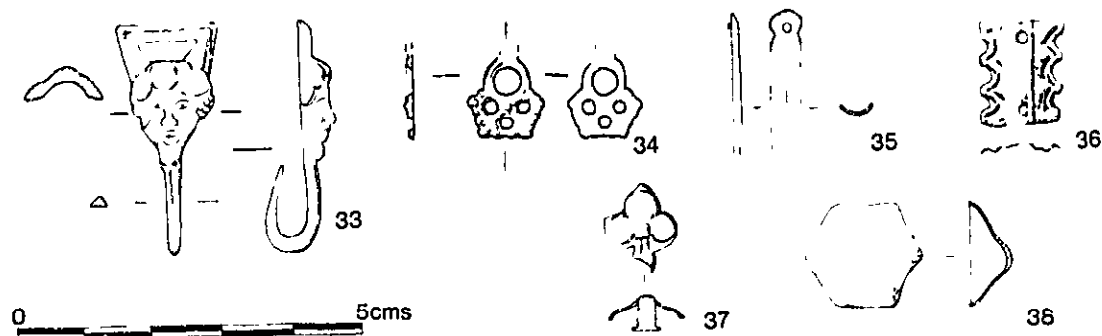

Fig.96

33. Hooked fastener. It has an angular loop for a strap or chain and the plate is decorated with a curly-haired human face. A similar hook from Bayham Abbey, Sussex, shows the face of a bearded man. [1] 75.25.33 A SF182, F70 L166, post-medieval context, modern service trench.
34. Possibly an eyelet or an incomplete hooked fastener with an ornamental plate. 75.25.34 A SF52, F90 L89, 13th-cent. context.
- 35-38. Strap ornaments. Nos.35-36 are repoussé mounts with holes for rivets. The trefoil stud, No.37, is cast and poorly finished at the edges. No.38 is a six-sided repoussé boss resembling the more common six-petalled rosettes.
35. 75.25.35 A SF1166, F1516 L2, 13th-cent. context;
36. 75.25.36 A SF1010, L2 (0.5M, 111.5/1015), unstratified;
37. 75.25.37 A SF1171, F1548, 14th-cent. context;
38. 75.25.38 A SF1121, L2 (2M, 108/998), unstratified.

1. A.R. Goodall, 'Objects of Copper Alloy' in A. Streeton, Bayham Abbey Sussex Archaeological Society Monograph 2 (1983), 109, Fig.48, No.5.

COPPER ALLOY OBJECTS

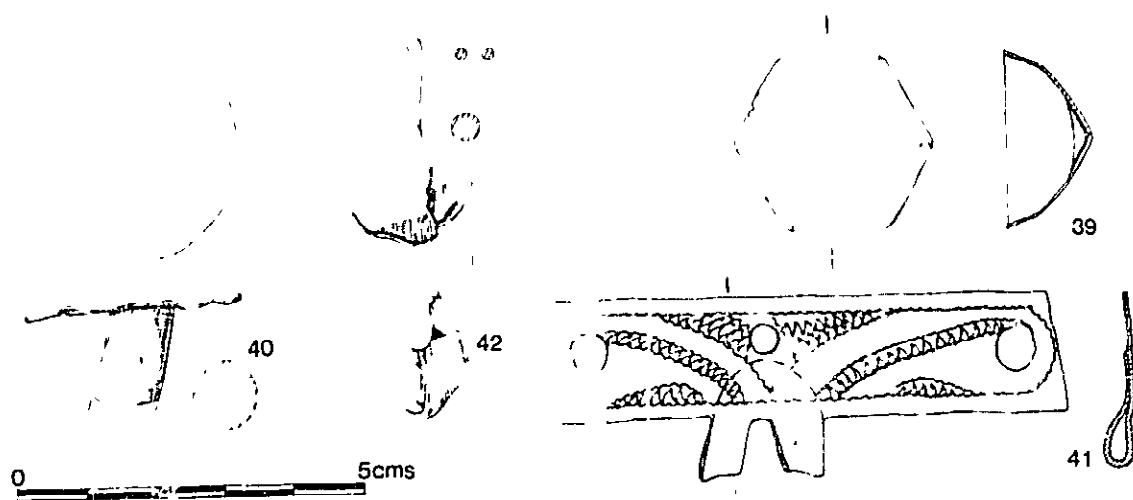

Fig. 97

- 39-40. Large studs. No. 39 has a domed hexagonal head.
39. 75.25.39 A SF1119, L2 (2M, 108/998), unstratified;
40. 75.25.40 A SF56, F52 L52, undated context.
41. Mounting for a pendant with traced decoration and gilding.
75.25.41 A SF538, F121 L235, 14th-cent. context.
42. Sheet metal bell with a pierced shank for suspension.
75.25.42 A SF109, F53 L45, 15th-cent. context.

COPPER ALLOY OBJECTS

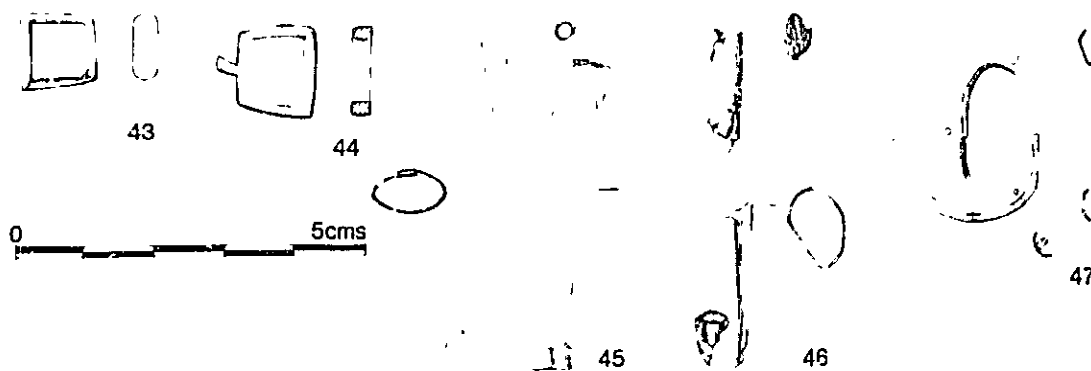

Fig. 98

- 43-44. Swivel loops.
 43. 75.25.43 A SF22, L2 (2M, 112/1014), unstratified;
 44. 75.25.44 A SF71, L2 (2M, 112/1008), unstratified.
- 45-46. Scabbard chapes. Both are made from sheet metal with the edges overlapping. No.45 has a rivet hole near the top edge and a separate strip of metal has been soldered round the lower edge. No.46 contains what may be the remains of a leather scabbard.
 45. 75.25.45 A SF93, L2 (0.5M, 117.15/1011.40), unstratified;
 46. 75.25.46 A SF1030, L2 (0.5M, 110/1007.5), unstratified.
47. Crescent- or D-shaped mount of sheet metal with down-turned edges. There are three rivet holes, one retaining a rivet. A similar crescent-shaped ornament was found at Chelmsford, Essex, [1] and was apparently a composite object, having a flat backing plate.
 75.25.47 A SF66, F53 L53, 15th-cent. context.

1. A.R. Goodall in C.M. Cunningham and P.J. Drury, Post-Medieval Sites and their Pottery: Moulsham Street, Chelmsford, C.B.A. Research Report 54 (1985), 45, Fig.29, No.48.

COPPER ALLOY OBJECTS

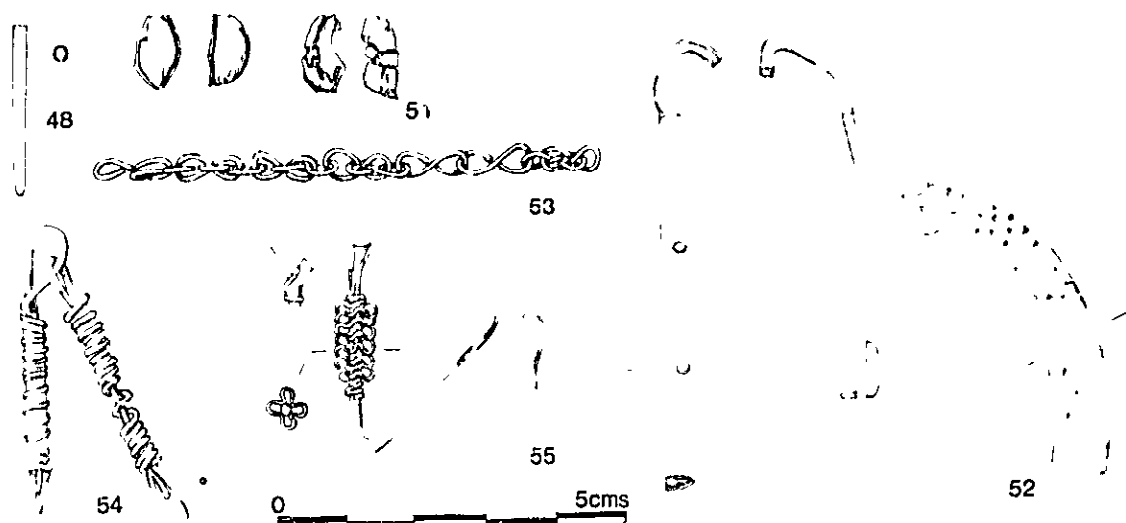

Fig.99

- 48-50. Lace ends of rolled sheet metal.
 48. A SF2012, L4, undated context;
 49-50. A SF2041, L2013, undated context. Not illustrated.
51. Fragments, probably from a small button with white metal plating.
 A SF1105, L1282 (= F1038 L1188), 14th-cent. context.
52. Part of a hoop from a purse frame with cross-hatch decoration.
 A SF2079, L2 (2M, 100/1008), unstratified.
- 53-54. Chains. No.53 is made up of S-shaped links and No.54 consists of two links each made from a single loop of wire with one free end bound round the middle of the loop.
 53. 75.25.48 A SF529, F115 L203, 13th-cent. context;
 54. 75.25.49 A SF74, F59 L101, 14th-cent. context.
55. Toilet implement, probably an ear-scoop, with a coil of wire wound round the stem. Very similar objects have been found at Kirkstall Abbey, Leeds, [1] and Netherton, Hampshire. [2]
 75.25.50 A SF130, L2 (2M, 112/1000), unstratified.

1. C.V. Bellamy & C.M. Mitchell, 'Kirkstall Abbey Excavations. Tenth Report, 1959', Publication of the Thoresby Society, (1960), 125, Fig.132.
2. A.R. Goodall in J. Fairbrother, forthcoming, No.132.

COPPER ALLOY OBJECTS

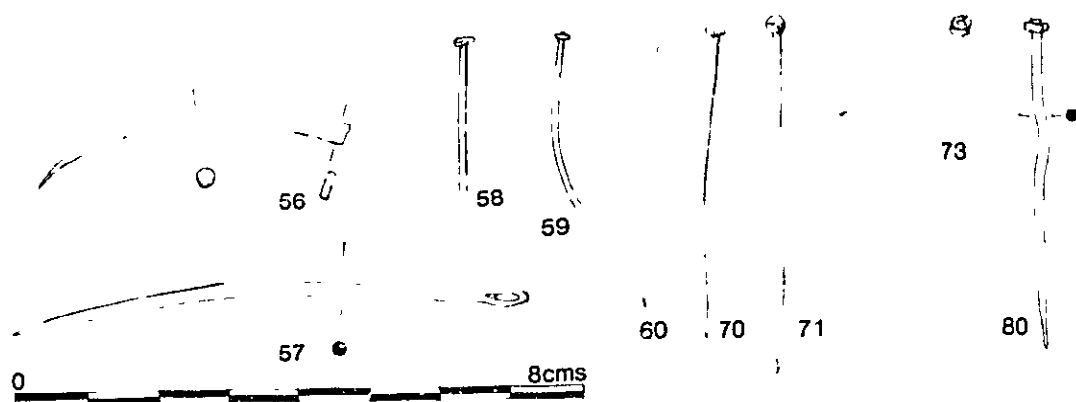

Fig.100

- 56-57. Needles. No.56 is broken through the eye. No.57 has a flattened perforated head.
56. A SF1153, F1517 L2, 13th-cent. context.
57. 75.25.51 A SF1090, L2 (2M, 104/1000), unstratified.
- 58-83. Pins. Eight lack heads; Nos.65, 69 and 70 have domed heads and the rest have heads of coiled wire. Nos.69-71 and 80 are long pins, varying in length between 40 and 50mm. Nos. 61-69, 72, 74-79, 81-83 are not illustrated.
58. A SF1160, F1537, 12th-cent. context;
59. A SF555, F157 L336, 13th-cent. context;
60. A SF1047, F1007 L1103, 13th-cent. context;
61. A SF2098, F2518 L1, 13th-cent. context;
- 62-63. A SF2047, L2007, undated context;
- 64-65. A SF2068, F2510 L1, 14th-cent. context;
- 66-68. A SF69, F53 L45, 15th-cent. context;
69. A SF86, F53 L138, 15th-cent. context;
70. A SF87, F53 L53, 15th-cent. context;
71. A SF1032, F1006 L1054, 15th-cent. context;
72. A SF2049, L2002, undated context;
73. A SF106, F47 L49, undated context;
74. A SF2022, F2554 L2016, 15th-cent. context;
- 75-79. A SF2032, L2013, undated context;
80. A SF2066, F4 (L4), 19th-cent. (undated) context;
- 81-82. A SF3055, F1019 L1102, 14th-cent. context;
83. A SF2070, L2013, undated context.

COPPER ALLOY OBJECTS

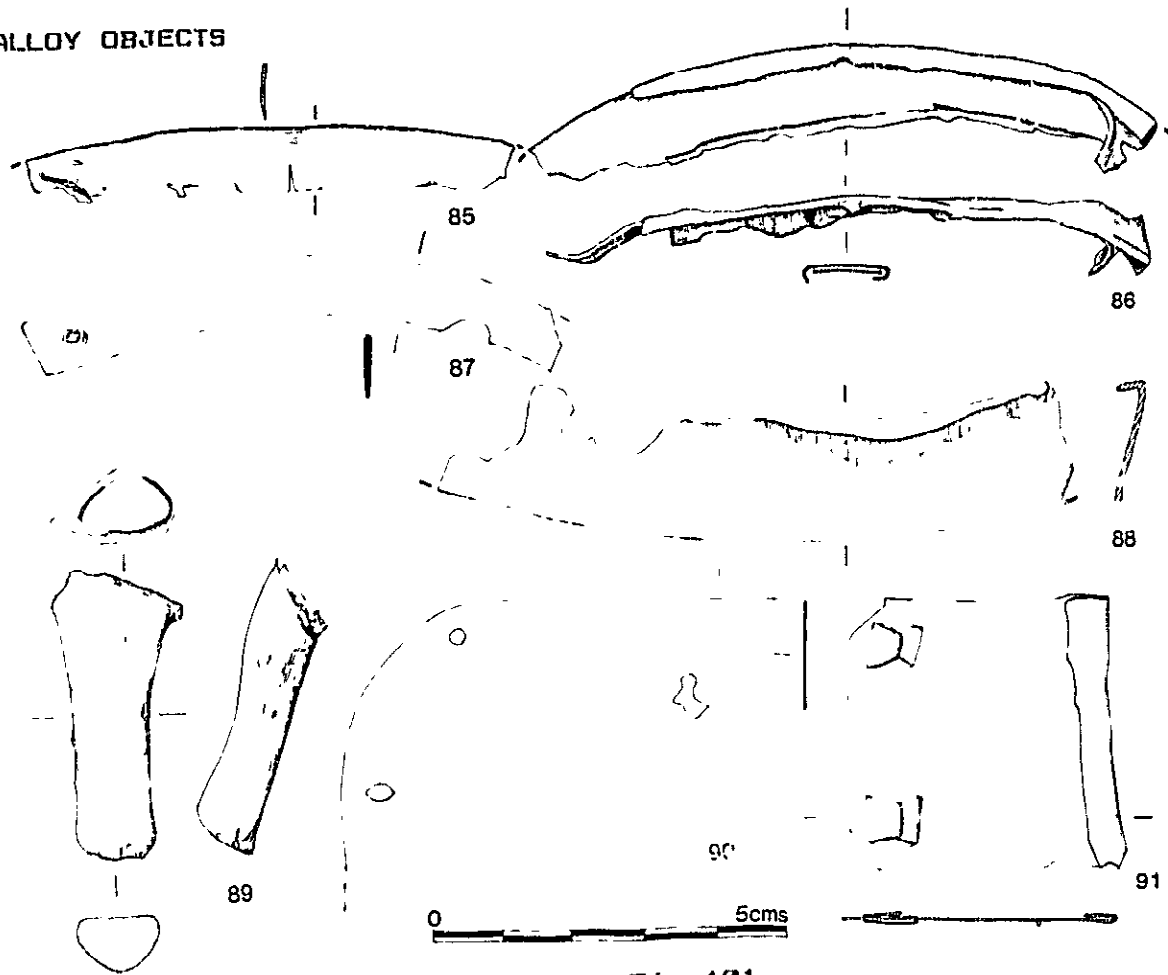

Fig.101

84-91. Vessel fragments. Nos.84-88 are fragments from rims and possible rims; Nos.86 and 88 are from sheet metal vessels. No.89 is a cauldron leg and Nos.90-91 are patches. No.84 is not illustrated.

- 84. A SF574, F109 L101, 13th-cent. context;
- 85. 75.25.52 A SF1038, F1006 L1053, 15th-cent. context;
- 86. 75.25.53 A SF1084, F1059 L1, 15th-cent. context;
- 87. A SF2104, L2 (2M, 102/996), unstratified;
- 88. 75.25.54 A SF33, L2 (2M, 100/1006), unstratified;
- 89. 75.25.55 A SF1118, L2 (2M, 108/996), unstratified;
- 90. 75.25.56 A SF2097, F2521 L1, 13th-cent. context;
- 91. 75.25.57 A SF501, F100 L170, undated context.

COPPER ALLOY OBJECTS

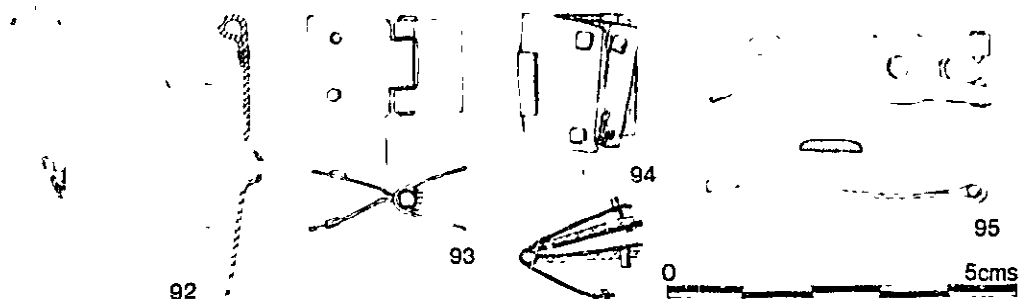

Fig.102

92. Oval hinged lid with a slot for fastening.
75.25.58 A SF59, F53 L53, 15th-cent. context.
- 93-95. Hinges. No.93 consists of two plates, one incomplete, with a pin of iron? No.94 retains fragments of leather(?) between the plates. No.95 is a shaped hinge strap.
93. 75.25.59 A SF2074, F2511 L2, 12th-cent. context;
94. 75.25.60 A SF561, F116, 13th-cent. context;
95. 75.25.61 A SF198, (F40) L377, test Pit.

COPPER ALLOY OBJECTS

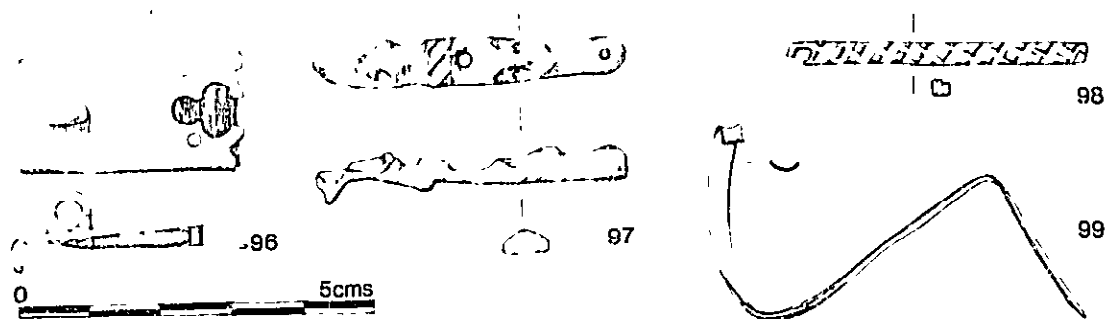

Fig.103

96. Hooked clasp with a loop on the upper plate, probably from a book binding. It may be compared with a similar object from Northampton [1] and with the looped strap end from Site B (No.137).
75.25.62 A SF1043, F1014 L1090, 15th-cent. context.
97. Hooked object, possibly a casket mount, with amorphous decoration. One iron rivet survives.
75.25.63 A SF2076, L2013. undated context.
98. Perforated strip with deeply incised lattice. It appears to have been cut down from a larger piece.
75.25.64 A SF1179, F1527 11, 12th-cent. context.
99. U-Sectioned binding strip without perforations.
75.25.65 A SF3017, F1014 L1090, 15th-cent. context.

1. G.E. Dakley in J.H. Williams, 'Excavations at Greyfriars, Northampton, 1972', Northamptonshire Archaeology, xiii (1978), 149, Fig.22, No.12.

COPPER ALLOY OBJECTS

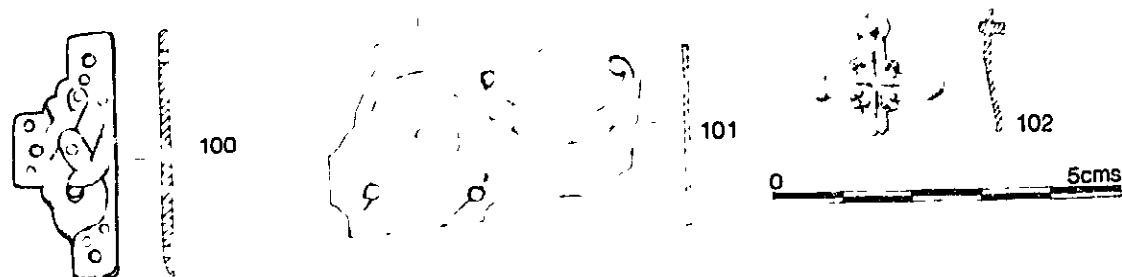

Fig. 104

- 100-102. Decorative mounts. No. 100 is decorated with interlace and stamped circles and may be from the arm of a cross. No. 101 has incised scroll ornament. No. 102 is a small cross-shaped mount with cast decoration; it has a single rivet.
- | | | |
|------|----------|--|
| 100. | 75.25.66 | A SF1077, F1057 L1, 15th-cent. context; |
| 101. | 75.25.67 | A SF1100, L1282 (= F1038 L1188), 14th-cent. context; |
| 102. | 75.25.68 | A SF88, L2 (0.5M, 115/1009.5), unstratified. |

COPPER ALLOY OBJECTS

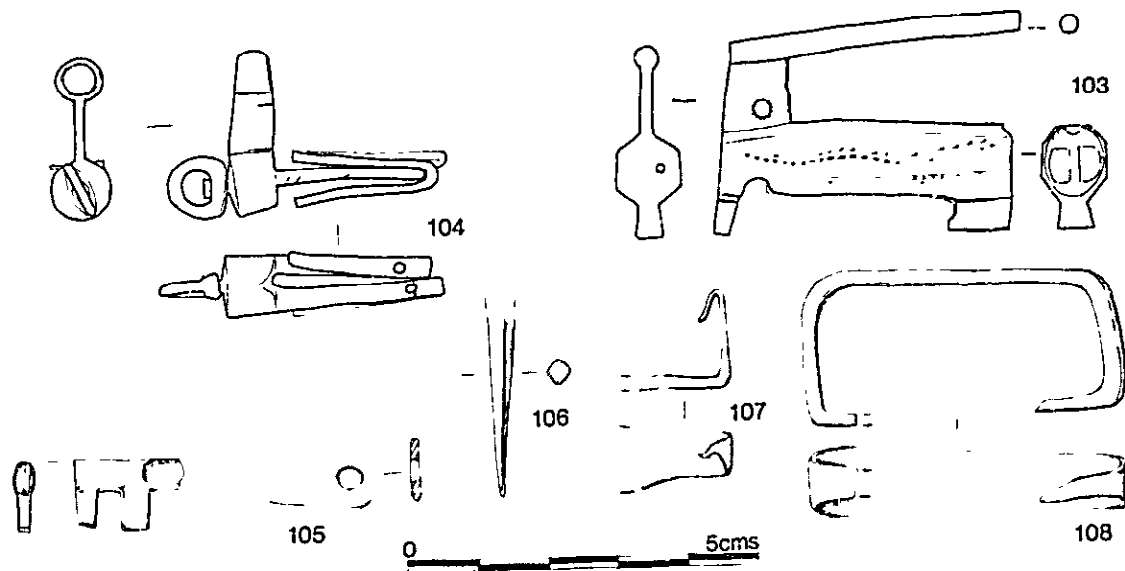

Fig.105

- 103-104. Padlock case and bolt. The hexagonal-sectioned case is decorated with traced or punched lines and the plate has openings for two springs on the bolt. The bolt has two springs each with a pair of leaves which have been made from strips folded over and riveted to the ends of the spines. Although found in different contexts it seems very likely that Nos.103-104 are parts of the same padlock.
103. 75.25.69 A SF2042, L2013, undated context;
104. 75.25.70 A SF1120, F1512 L2, 13th-cent. context.
105. Key with flat perforated head.
75.25.71 A SF8, L2 (2M, 102/1004), unstratified.
106. Nail or tack with tapering shank. The head is missing.
A SF2073, F2512 L1, undated context.
- 107-108. Staples.
107. A SF2108, F2532, 13th-cent. context;
108. A SF2105, L2 (2M, 102/996), unstratified.

COPPER ALLOY OBJECTS

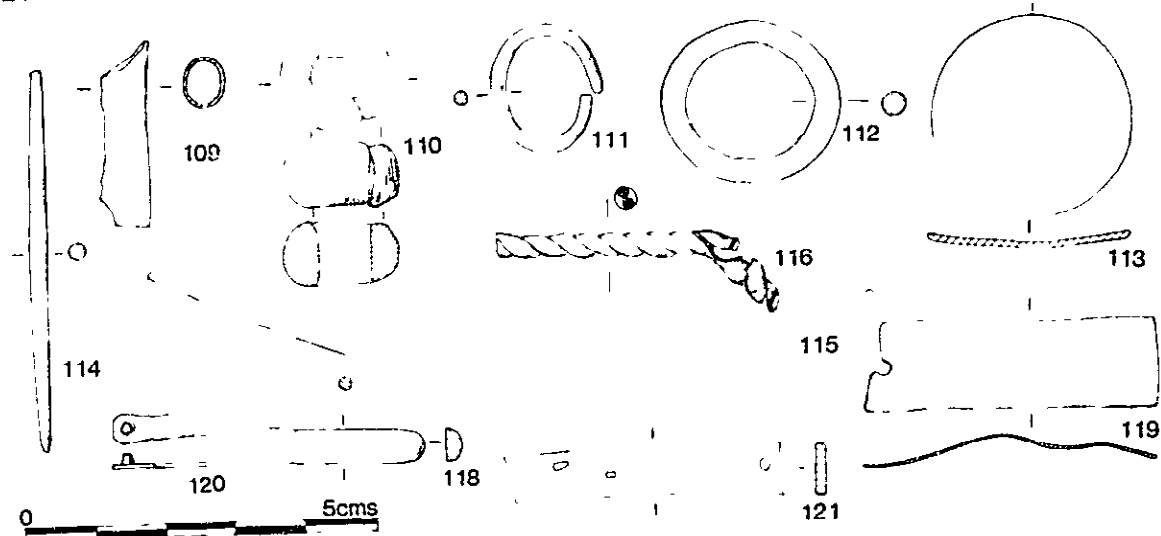

Fig.106

109. Incomplete cylinder blocked at one end.
A SF2254, F2502, 14th-cent. context.
- 110-117. Rings. Nos.110-111 are penannular, No.110 being made from a D-sectioned bar. No.112 is a round-sectioned ring.
110. 75.25.72 A SF112, F53 L53, 15th-cent. context;
111. 75.25.73 A SF2013, L2013, undated context;
112. 75.25.74 A SF1125, F1022 L1119, 15th-cent. context.
113. Corroded disc.
A SF533, L2 (0.5M, 117.5/1013.5), unstratified.
114. Rod, slightly tapering at both ends.
A SF1176, F1556, 11th-cent. context.
- 115-116. Wire. No.116 consists of two strands of thick wire twisted together.
115. A SF1022, F1006 L1054, 15th-cent. context;
116. A SF1114, L2 (2M, 110/998), unstratified.
- 117-122. Strips. Nos.117-118 are D-sectioned and may be from gilt bindings. Nos.119-120 are riveted and No.119 has what appears to be a trace of gilding. Nos.117 and 122 are not illustrated.
117. A SF2128, F2505 L3, 12th-cent. context;
118. A SF1130, F1022, 15th-cent. context;
119. 75.25.74 A SF511, F109 L181, 13th-cent. context;
120. A SF560, F154 L362, 13th-cent. context;
121. A SF539, F121 L235, 14th-cent. context;
122. A SF2138, L2013, undated context.

COPPER ALLOY OBJECTS

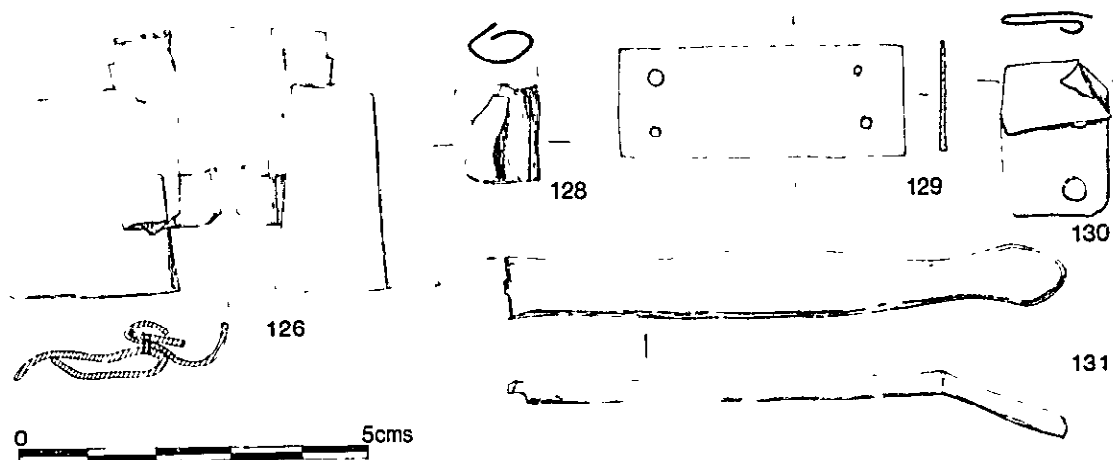

Fig.107

- 123-130. Fragments and off-cuts of sheet metal. No.126 consists of several pieces that have been riveted together. No.128 has been rolled to form a cylinder. Nos.123-25, 127 are not illustrated.
123. A SF2120, F2537, 11th-cent. context;
 124. A SF2146, F2517 L1, 12th cent. context;
 125. 75.25.76 A SF534, F121 L235, 14th-cent. context;
 126. 75.25.77 A SF1054, F1014 L1090, 15th-cent. context;
 127. 75.25.78 A SF128, L2, unstratified;
 128. A SF1013, L2 (2M, 110/1006), unstratified;
 129. 75.25.79 A SF1075, L2 (2M, 110/994), unstratified;
 130. 75.25.80 A SF1129, L2 (2M, 104/994), unstratified.
- 131-132. Small amounts of spillage from casting. No.132 is not illustrated.
131. A SF557, L350, 11th + 13th- to 14th-cent. finds from context;
 132. A SF217, L1, unstratified.
133. Slag. Not illustrated.
 A SF196, F53 L53, 15th-cent. context.

COPPER ALLOY OBJECTS



Fig.108

Site B, Greyfriars

134. Wire fragment, maximum thickness 2mm, tapering towards both ends. Probably a distorted ear- or finger ring, comparable to examples from Thetford dating from the late Saxon period. [1] Not illustrated.
75.27.1 B II SF5, L2, undated context.
135. Probable ear- or finger-ring, made from 2mm thick wire with overlapping ends.
75.27.2 B II SF17, L1, unstratified.
136. Ring; possibly an annular buckle or brooch lacking the pin. A similar but smaller example from Leicester had the remains of a leather strap attached to it confirming its use as a buckle rather than a brooch. [2]
75.27.3 B II SF23, F31, undated context (disturbed burial).
137. Looped strap-end probably from a book binding. Two rectangular plates, the upper having two incised lines along each of its long sides and a small loop, soldered or brazed together at one end, and enclosing the end of a leather strap.
75.27.4 B II SF24, unstratified.

1. A.R. Goodall, 'Non-ferrous Metal Objects' in A. Rogerson and C. Dallas, Excavations in Thetford, 1948-59 and 1973-80, East Anglian Archaeology 22 (1984), 69, Fig.110, Nos.17-21.
2. P. Clay in J.E. Mellor and T. Pearce, The Austin Friars, Leicester, C.B.A. Research Report 35 (1981), 133 Fig.48.24.

COPPER ALLOY OBJECTS

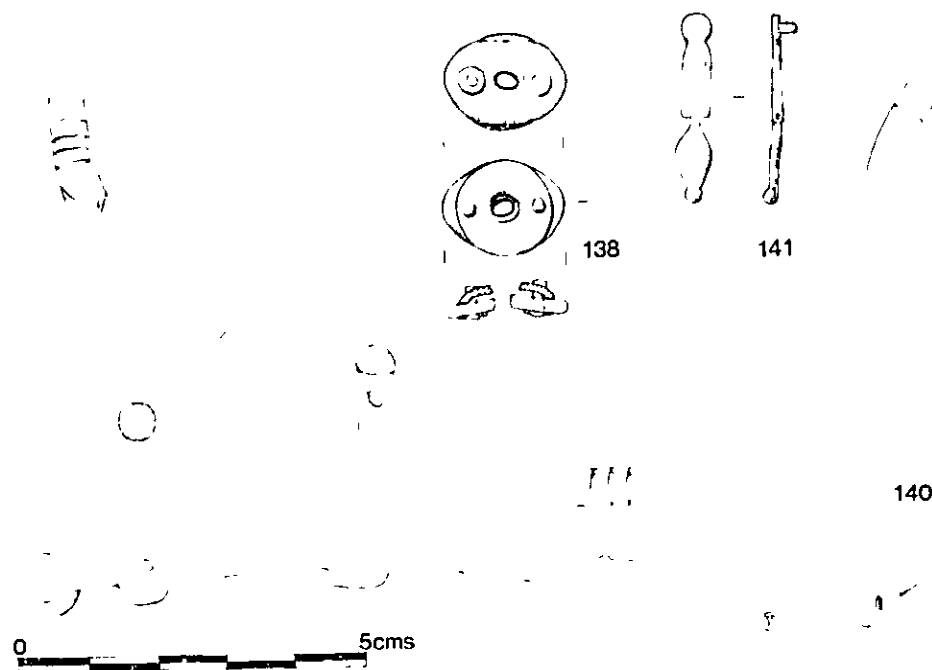

Fig.109

- 138-139. Eyelets. No.138 is attached to a piece of leather by two copper alloy rivets secured by washers on the back; No.139 (not illustrated) is similar, 17mm in diameter.
 138. 75.27.18 B IV SF36, L5, 16th-cent. context;
 139. 75.27.5 B VI SF44, L21, undated context.
140. Hoop from a purse-frame (incomplete). It has traces of linear decoration and five remaining loops for suspension of the bag.
 75.27.6 B VI SF13 and 16, L1, unstratified.
141. Pendant with mounting and shank for attachment.
 75.27.7 B VII SF9, F6, mid 13th-cent. context.

COPPER ALLOY OBJECTS



Fig.110

- 142-143. Two letters from monumental brasses. Dr. John Blair writes: The two letters are of 'Main Group' form. [1] The A, No.142, is 43mm high (Size II) and 2mm thick, with the front smooth and the back rough from casting; the edges are filed, but traces remain of overspill from the mould. The R, No.143, is 38mm high (Size III), 3mm thick and is unusual in that it appears to have been cast in a reversed mould, the smooth back of the letter being downmost in the open mould and the front uppermost. (A N from St. Augustine's Canterbury, now in the Victoria and Albert Museum, also has this peculiarity.) The roughness from the surface of the casting has not been entirely removed from the front of the letter, and no attempt has been made to file the very conspicuous casting overspill from the edges.
- Both letters fall within the Main Group date-range (c.1300-1350) but cannot yet be more closely dated.
142. 75.27.8 B X SF3, unstratified.
143. 75.27.9 B II SF1, L1, unstratified.

J. Blair, 'English Monumental Brasses before the Black Death', in A. Detsikas (ed.), Collectanea Historica: Essays in Memory of Stuart Rigold (Kent Archaeological Society, 1981), 259 - 60.

COPPER ALLOY OBJECTS

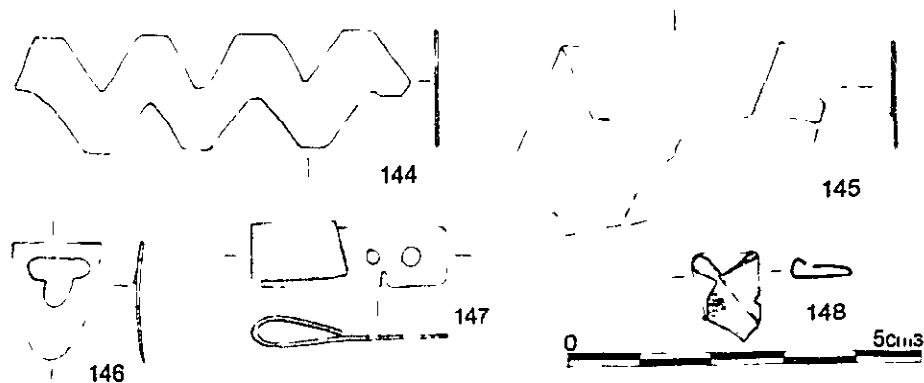

Fig.111

144. Zig-zag strip, incomplete at both ends, cut from sheet metal 0.3-0.5mm thick.
75.27.10 B II SF6, FB, undated context (burial).
145. Patch made from sheet metal.
75.27.11 B IV SF50, 124, undated context.
146. Perforated heater-shaped object.
75.27.12 B XXXIII SF11, F21, undated context.
147. Strip with two unequal sized perforations near one end.
75.27.13 B XXXIII SF13, F29, undated context.
148. Rectangular plate with sides c.10-12mm; three of its corners folded towards the centre. Possibly scrap.
B II SF15, F27, undated context (burial).

COPPER ALLOY OBJECTS

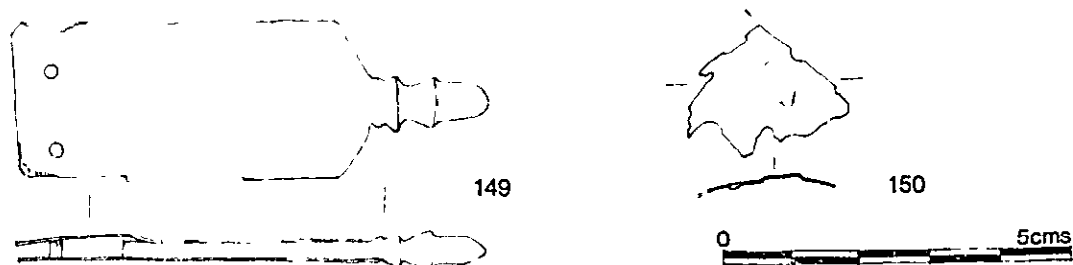

Fig.112

Site D, Littlegate

149. Strap-end. Undecorated plates enclose a forked central piece with a terminal knob; there are two copper alloy rivets in situ.
75.33.1 D I SF32, L3, unstratified.
150. Sheet fragment with repoussé lozenge.
75.33.2 D I SF37, L37, late 13th- to early 14th-cent. context.
151. Small washer, diameter 45mm. Not illustrated.
D I SF39, L41, late 13th-cent. context.

COPPER ALLOY OBJECTS

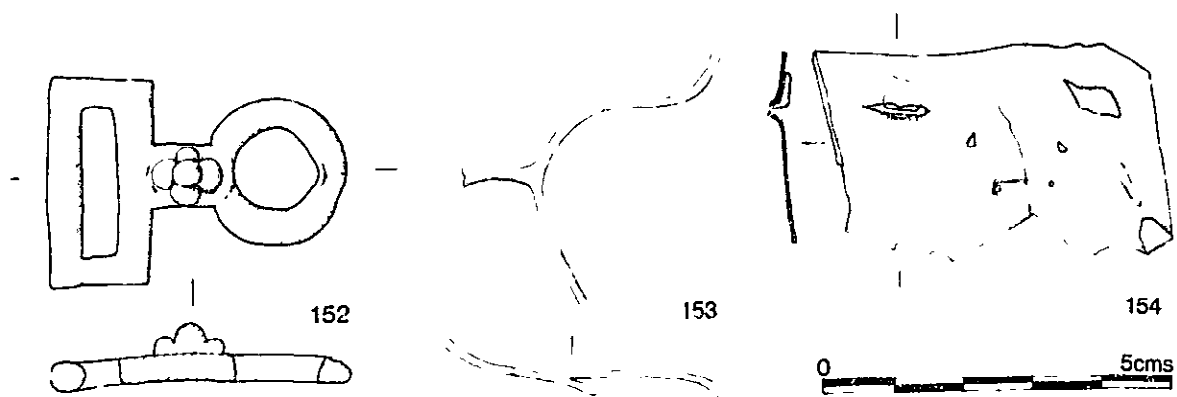

Fig. 113

Site SEL, Selfridges; Spur by Blanche Ellis

152. Belt or strap fastener decorated with an applied rosette; the strap would have passed through the rectangular loop. The smaller ring shows signs of wear from being used with a hook.
75.35.1 SEL SF12, F18, 12th- to 13th-cent. context.
153. Spur, intrusive. Blanche Ellis writes:- Copper alloy spur fragment of very slender proportions. Heavily encrusted with soil embedded in its corroded surfaces. The sides appear to have been horizontally straight, they are now distorted, their front ends with terminals are missing. The neck is slightly curved. It is broken 20mm, along its length where an indentation suggests that a missing rowel box began to divide it.
Overall length c.70mm. Length of broken neck 22mm.
Typology. The present state of this fragment makes it impossible to identify its type with absolute certainty but it appears to have been a slender, straight-sided rowel spur of the late 17th or 18th century.
75.35.2 SEL SF19, F53, 12th-cent. context.
154. Patch with slots for folded sheet metal rivets or clips.
75.35.3 SEL SF9, F23, 12th- to 13th-cent. context.

COPPER ALLOY OBJECTS

Site W, Westgate

W SF58 F89 Not identifiable.
W SF59, F89 Not identifiable.

M III B12

LEAD AND LEAD ALLOY OBJECTS by GEOFF EGAN (NOS.1-24) and ALISON GOODALL
(NOS.25-28)

Figs.114-118

Site A: 1-23; Site B: 24-28.

Site A, 31-34 Church St. by Geoff Egan [1]

This report was prepared in 1978 and does not take account of subsequent research.

1-8. Styli:

Styli with pointed ends for writing and flattened ends for erasure (cf. Roman styli). These items were probably used for drawing the guidelines for placing words on manuscripts, although they could have been used for wax tablets. [2] Similar objects were found at the Dominican priory, Oxford. [3]

1. I am grateful to Mr. Brian Spencer for his assistance with Nos.6 and 9.
2. Cf. Pl. in J.M. Baart et al, Opgravingen in Amsterdam, (Haarlem, 1977), 382.
3. G. Lambrick & H. Woods, 'Excavations on the Second Site of the Dominican Priory, Oxford', Oxoniensia, xli (1976), 216-17; Fig.12, Nos.29-30.

LEAD AND LEAD ALLOY OBJECTS

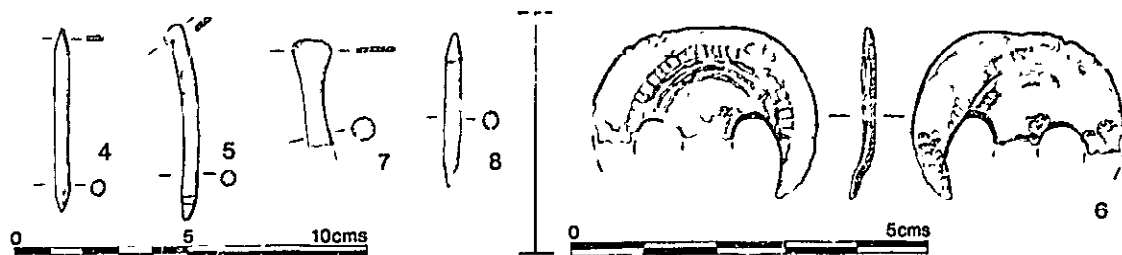

Fig.114

1. Rod. Pointed at one end, folded over at the other. Length 81mm. Not illustrated.
75.25.81 A SF2059, L2 (2M, 102/1014), unstratified.
 2. Rod, bent and broken at both ends. Possibly a stylus shaft. Not illustrated.
75.25.82 A SF2052, F15 L13, mid 18th-cent. context.
 3. Off-cut possibly used as a stylus; it has a rounded pointed end. Length 60mm. Not illustrated.
A SF3068, L1279 (= L2), unstratified.
 4. Stylus with pointed and flattened ends. Length 52mm.
75.25.83 A SF3052, F1510, 13th-cent. context.
 5. Complete stylus (?) with a flattened head. Length 58mm.
75.25.84 A SF3015, F1511 L1, 13th-cent. context.
 6. Concentric object with traces of patterning in relief. Broken. Brian Spencer suggests that this and a closely comparable fragment with an adjoining ring (B X SF2, unstratified; Cat. No.24) are the heads of styli. Complete styli with heads of this type are known from the Seine region and are thought to have been made in Paris [1] (now in the Musée de Cluny).
75.25.85 A SF1193, F1516, 13th-cent. context.
 7. Wide diameter shaft with a flattened head.
75.25.86 A SF2136, F2513 L4, 14th-cent. context.
 8. Short rod pointed at both ends. There is a groove or neck around the shaft near each point. Length 43mm.
75.25.87 A SF3330, F2532, 13th-cent. context.
-
1. Victor Gay, Glossaire Archéologique I, (1929), 491 third from the left.

LEAD AND LEAD ALLOY OBJECTS



Fig.115

9. Souvenir badge of Henry VI of Windsor, depicting the king crowned and holding an orb and sceptre against a diaper background. It retains part of the integrally-moulded pin on the back. The cult of Henry VI was fostered under Henry VII as a means of emphasising the links between the reigning king and his venerated predecessor, and hence the legitimacy of the Tudor claim to the throne. Late 15th century or early 16th century. Several similar badges are known including a number found in London. [1]
75.25.88 A SF42, L2 (2M, 110/996), unstratified.

1. E. Spencer, 'King Henry of Windsor and the London Pilgrim', in J. Bird, M. Chapman and J. Clark (eds.), Collectanea Londoniensis, London and Middlesex Archaeological Society Special Paper No.2, (1978), 235-64. The Church Street example is No.11 in this paper.

LEAD AND LEAD ALLOY OBJECTS

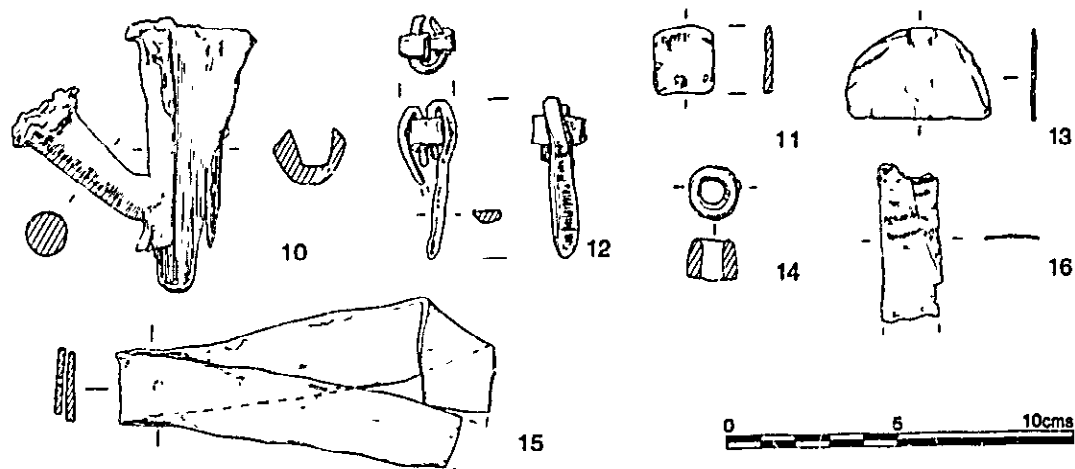

Fig.116

10. Setting for an iron fitting, (? railing setting).
75.25.89 A SF3111, L2, unstratified.
11. Cut fragment of sheeting with a hole.
75.25.90 A SF1110, L2 (2M, 110/1002), unstratified.
12. Three strips, folded together, cut from sheeting.
A similar object is known from East Haddesley in Yorkshire. [1]
75.25.91 A SF1092, L2 (2M, 106/1004), unstratified.
13. Semi-circular piece, cut from sheeting.
75.25.92 A SF594, F140 L291, 13th-cent. context.
14. Irregular piping (?). Worn at the narrower end, cut (?) at the thicker end.
75.25.93 A SF559, L356, undated context.
15. Strip with a nail (?) hole, cut from sheeting.
75.25.94 A SF1015, F1006 L1062, 15th-cent. context.
16. Irregular sheeting strip. Broken at both ends.
75.25.95 A SF1128, F1053 L2, 12th-cent. context.

1. H.E.J. le Patourel, The Moated Sites of Yorkshire, Society for Medieval Archaeology Monograph No.5 (1973), 90-91; Fig.37, No.28, derived from 15th- to 16th-century destruction levels.

LEAD AND LEAD ALLOY OBJECTS



Fig.117

- 17-22. Sheet off-cut (only No.18 is illustrated):
- 17. A SF187, F53 L53, 15th-cent. context;
 - 18. A SF1198, F1548, 14th-cent. context;
 - 19. A SF2158, F2501 L1, 13th-cent. context;
 - 20. A SF2230, F2503 L1, 12th-cent. context;
 - 21. A SF2226, F2517, 12th-cent. context;
 - 22. A SF2107, F2533, 11th-cent. context.

23. 12 solidified molten runnels were found in a number of contexts. Only one is illustrated, No.23. Further details are recorded in the site archive.

LEAD AND LEAD ALLOY OBJECTS

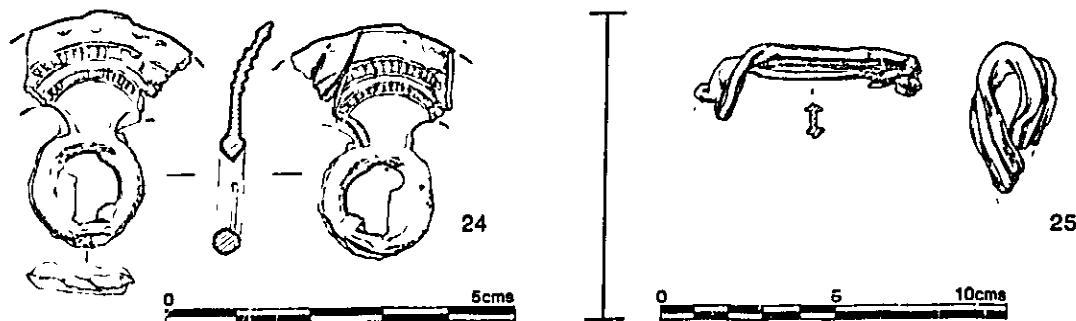

Fig.118

Site B, Greyfriars by Alison R. Goodall (except No.24)

24. Head of a stylus. Cf. Cat. No.6.
75.27.14 B X SF2, unstratified.
- 25-26. Fragments of H-section window leads. Only No.25 is illustrated.
25. B IV SF32, L4, 16th-cent. + context;
26. B VI SF30, F22, post-medieval context.
27. Convex fragment. Width 46mm. Varying in thickness from 3-5mm. Not illustrated.
B X SF21A, F6, Phase IX.
28. Two fragments of flashing. Varying thickness from 0.5-2.5mm. Not illustrated.
B XXXIII SF9, L32, early to mid 13th-cent. context.

M III C5

IRON OBJECTS by IAN H. GOODALL; SPUR by BLANCHE ELLIS

Figs. 119-146

Site A: 1-140; Site B: 141-46; Site D: 147-50; Site SEL: 151-57; Site W:
158-60.

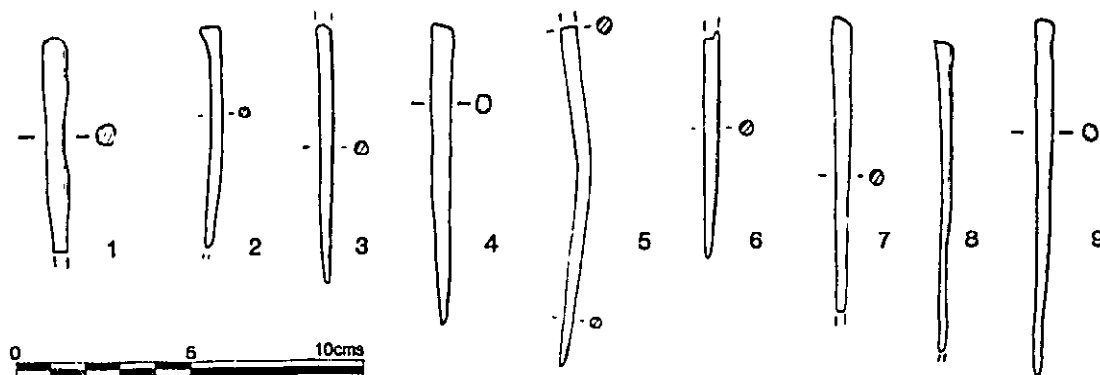

Fig. 119

Site A, 31-34 Church St.

1-14. Tools:

1-9. Teeth from woolcombs or heckles used respectively to prepare wool or flax fibres for spinning. All except Nos. 4-5 are broken; No. 4 is 86mm long; No. 9 is 101mm long.

1. A SF134, L135/1, undated context;
2. A SF2244, F2515 L2, 12th-cent. context;
3. A SF2246, F2515 L2, 12th-cent. context;
4. A SF1197, F1538, 12th-cent. context;
5. A SF1254, F1527 L1, 12th-cent. context;
6. A SF2241, F2516 L2, 13th-cent. context;
7. A SF2235, F2521 L1, 13th-cent. context;
8. A SF2127, F2522, 13th-cent. context;
9. A SF584, F116, 13th-cent. context.

IRON OBJECTS

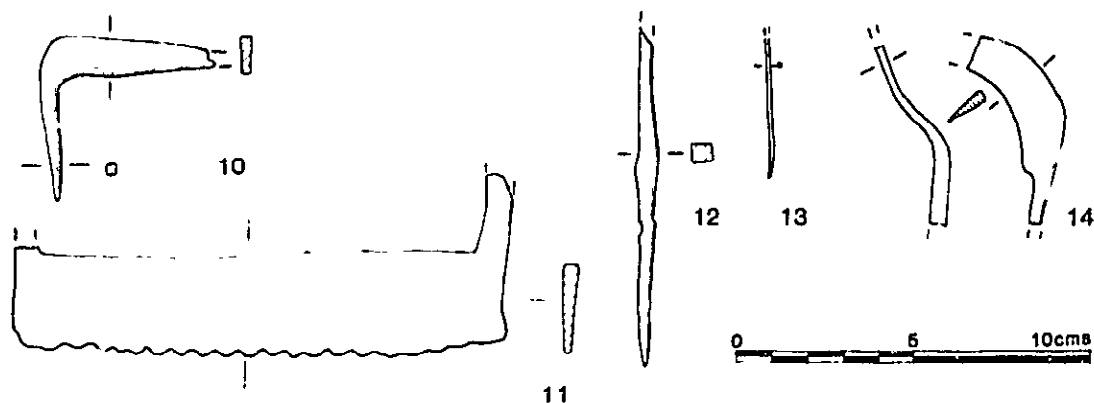

Fig.120

10. Tenter hook with broken shank originally driven into a wooden frame on which cloth was stretched to dry.

A SF597, F59 L179, 14th-cent. context.

11. Slicker used during the currying of leather to force dirt out of hides and to rub grease in. The blade edge is serrated in contrast to the plain edge of most medieval slickers. All have, or had, tangs at each end for mounting in a wooden handle.

75.25.96 A SF1302, F1035 L1252, 13th-cent. context.

12. Awl. A SF2127, F2522, 13th-cent. context.

13. Needle, eye lost, 40mm long, 1mm diameter.

A SF132, L135/3, undated context.

14. Tanged weedhook, the blade originally semicircular but now broken and distorted.

75.25.97 A SF2237, F2517 L1, 12th-cent. context.

IRON OBJECTS

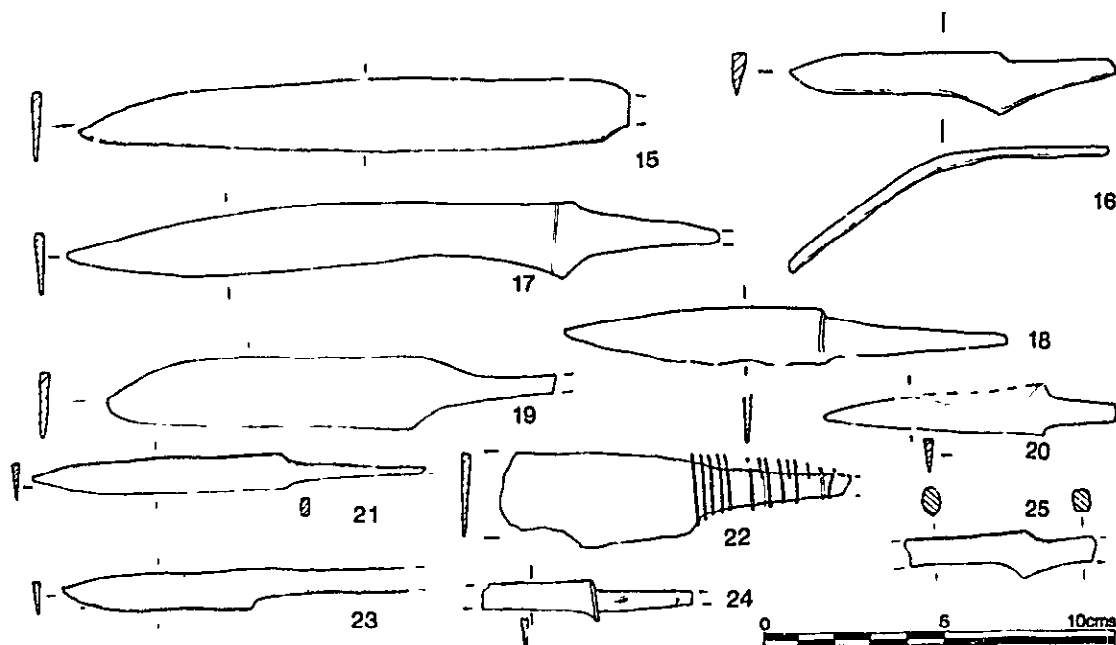

Fig.121

15-44. Knives and Shears:

Nos.15-43 are knives, Nos.15-31 with whittle tangs, Nos.32-37 mostly just scale tangs, and Nos.38-43 blade fragments. The whittle tang knives are grouped by blade shape, and No.22 and No.30 have sheet metal plates originally interleaved with others of organic material at the junction of tang and blade. The scale tang knife handle, No.34, has a copper alloy end cap, but the rivets of Nos.34-35 are of iron. No.44 is a shears blade.

- 15. 75.25.98 A SF2145, F2517 L1, 12th-cent. context;
- 16. A SF618, F500, 11th-cent. context;
- 17. A SF154, F84 L9, 11th-cent. context;
- 18. 75.25.99 A SF3300, F116, 13th-cent. context;
- 19. A SF2119, F2541, 13th-cent. context;
- 20. A SF604, L378, undated context;
- 21. 75.25.100 A SF1286, F1014 L1090, 15th-cent. context;
- 22. A SF155, F84 L9, 11th-cent. context;
- 23. A SF137, L135/4, undated context;
- 24. 75.25.101 A SF2245, F2515 L2, 12th-cent. context;
- 25. A SF3016, F1003, 13th-cent. context;

IRON OBJECTS

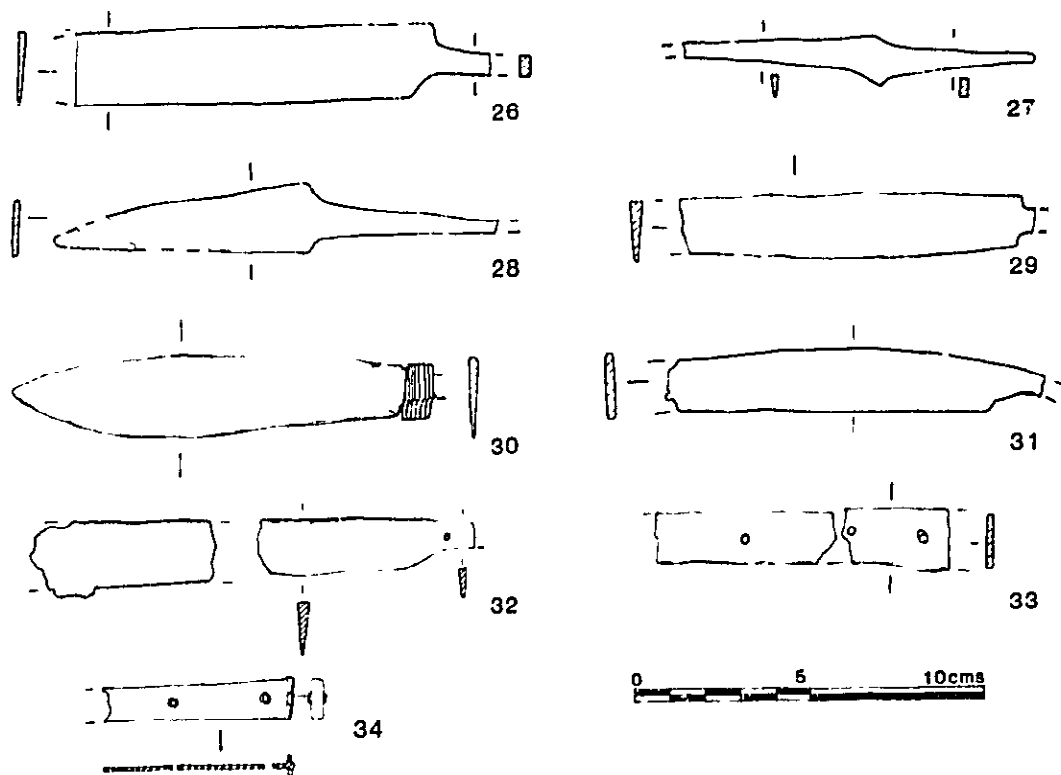

Fig.122

- 26. A SF2116, F2541, 13th-cent. context;
- 27. 75.25.102 A SF1270, F1519 L2, 11th-cent. context;
- 28. A SF615, F501, 13th-cent. context;
- 29. A SF620, F512, 10th-cent. (or earlier) context;
- 30. A SF99, F100 L170, undated context;
- 31. A SF2121, F2515 L2, 12th-cent. context;
- 32. A SF1299, F1030 L1219, 15th-cent. context;
- 33. A SF1306, F1006 L1106, 15th-cent. context;
- 34. A SF1291, F1019 L1102, 14th-cent. context;

IRON OBJECTS

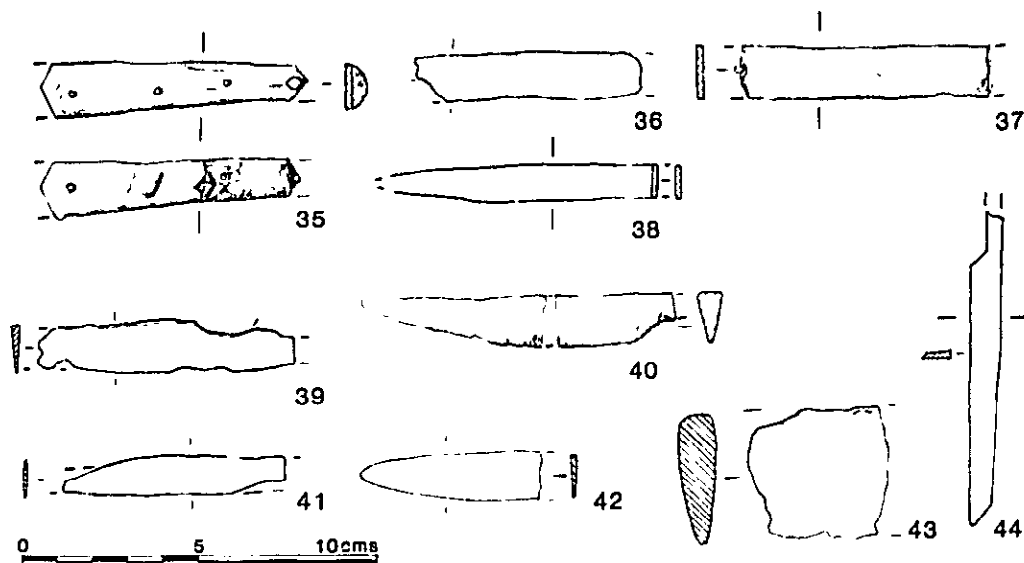

Fig.123

- 35. A SF166, F59 L101, 14th-cent. context;
- 36. A SF1284, F1006 L1063, 15th-cent. context;
- 37. A SF644, F53 L45, 15th-cent. context;
- 38. A SF150, F84 L9, 11th-cent. context;
- 39. A SF1215, F1515 L1, 12th-cent. context;
- 40. A SF659, F75 L243, 13th-cent. context;
- 41. A SF3013, F1051 L1, 13th-cent. context;
- 42. A SF1133, F1022, 15th-cent. context;
- 43. A SF1282, F1006 L1063, 15th-cent. context;
- 44. A SF3024, F1057 L1, 15th-cent. context.

IRON OBJECTS

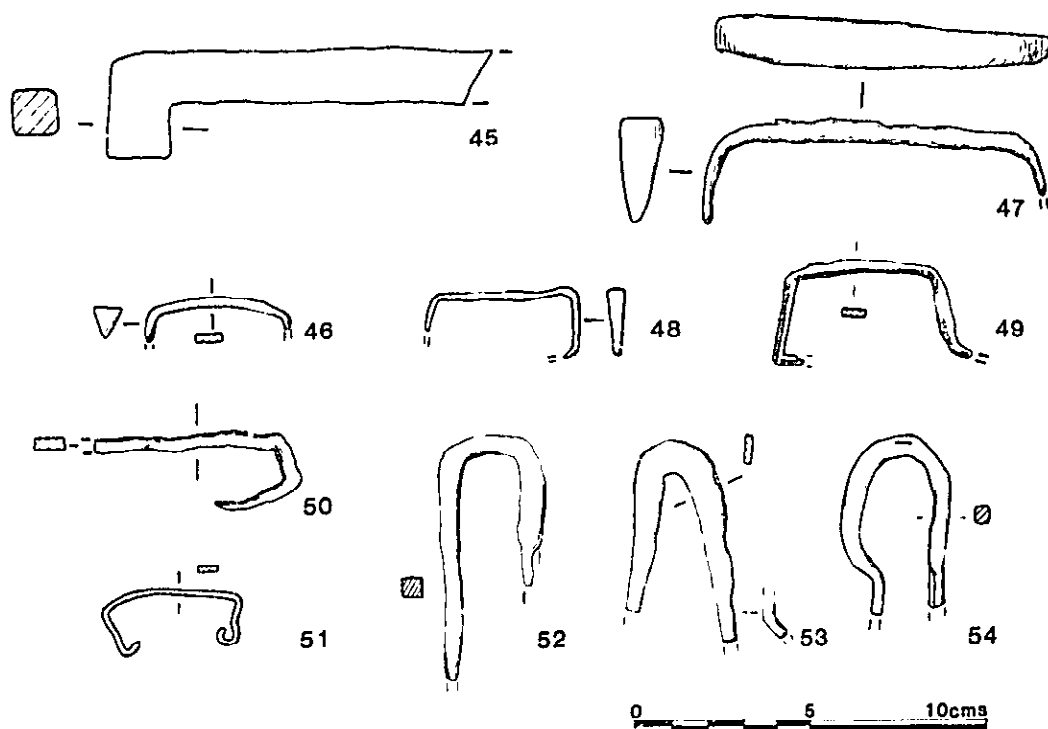

Fig.124

45-82. Building Ironwork:

45. Masonry cramp.

A SF602, F502, 10th-cent. (or earlier) context.

46-54. Staples. Nos.46-52 are rectangular with variously shaped arms, Nos.53-54 are U-shaped.

46. A SF664, F97 L139, 13th-cent. context;

47. A SF542, F124 L249, 13th-cent. context;

48. A SF2232, F2515 L1, 12th-cent. context;

49. 75.25.103 A SF552, F144 L314, 13th-cent. context;

50. A SF148, F84 L6, 11th-cent. context;

51. 75.25.104 A SF126, L135, undated context;

52. A SF527, F113 L197, 13th-cent. context;

53. A SF554, F145 L316, 13th-cent. context;

54. A SF3033, F1057, 15th-cent. context;

IRON OBJECTS

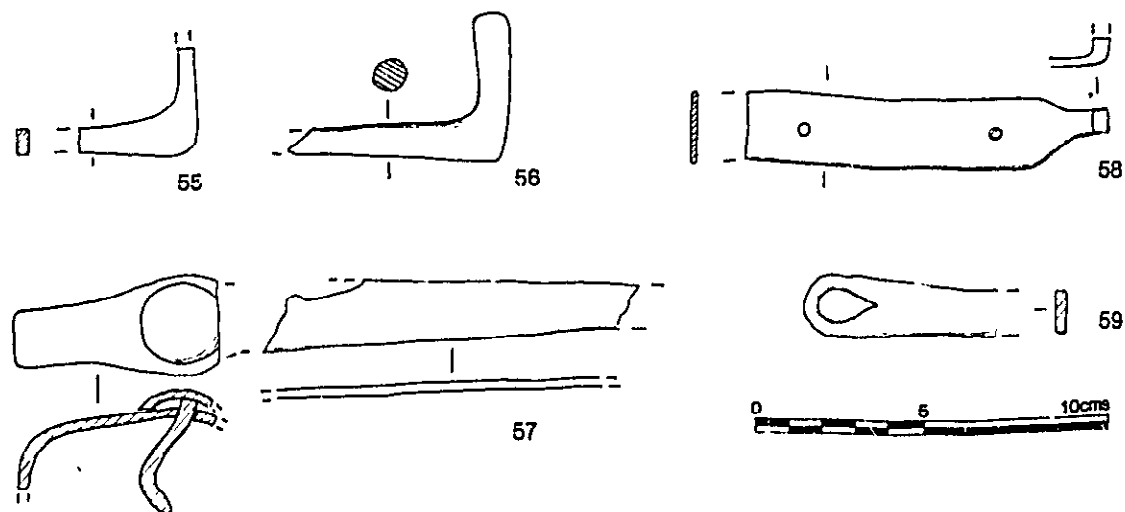

Fig.125

55-56. Hinge pivots.

55. A SF581, F116, 13th-cent. context;

56. A SF1281, F1006 L1063, 15th-cent. context.

57-68. Strap hinges. Nos.57-58 have broken U-shaped eyes and No.59, which may be from a stapled hasp rather than a hinge, has a looped eye. Nos.60-61 are pinned hinges, Nos.62-68 are lengths of strap of differing widths.

57. A SF2122, F2506 L11, 13th-cent. context;

58. 75.25.105 A SF1283, F1006 L1062, 15th-cent. context;

59. A SF1316, L2041, undated context;

IRON OBJECTS

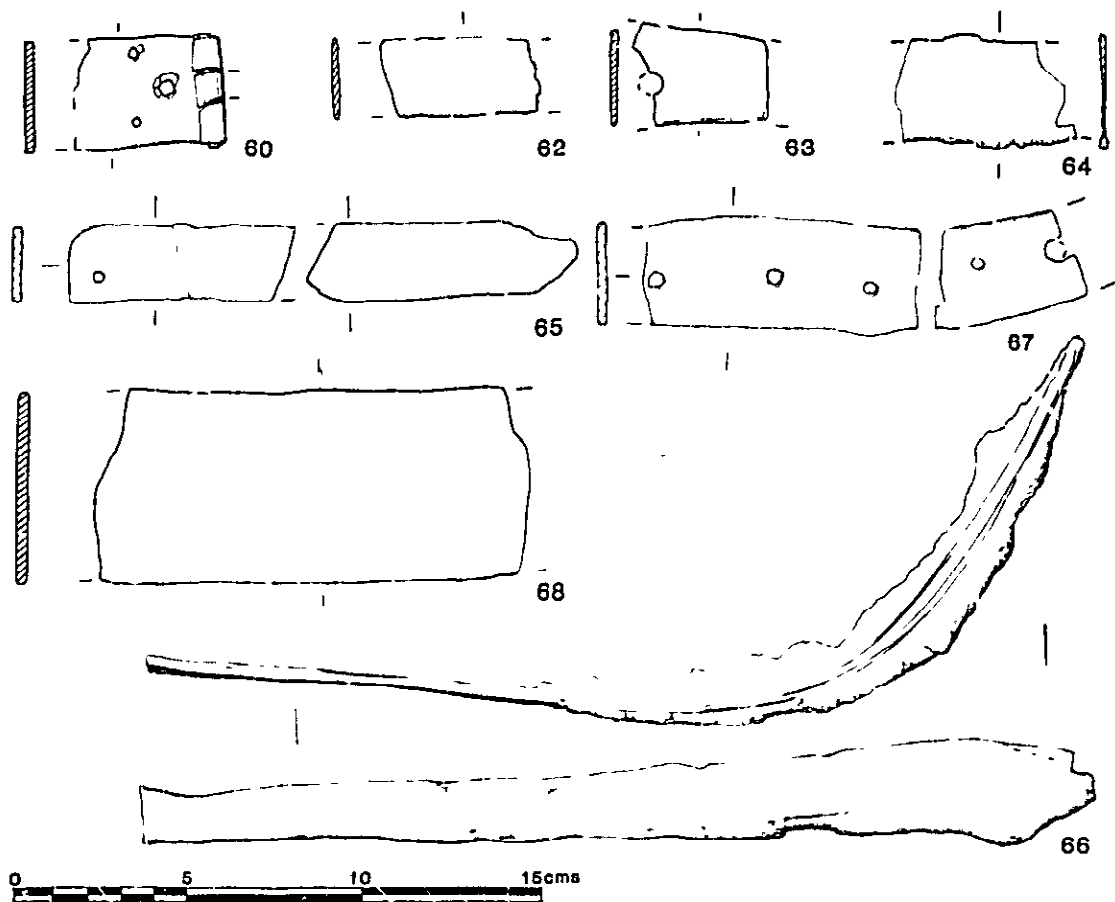

Fig. 126

- 60. A SF1290, F1019 L1102, 14th-cent. context;
- 61. A SF3331B, L2013, undated context, not illustrated;
- 62. A SF151, F84 L9, 11th-cent. context;
- 63. A SF3040, F1503 L1, 11th-cent. context;
- 64. A SF156, F84 L10, 11th-cent. context;
- 65. A SF1313, F2007 L2025, undated context;
- 66. A SF1094, F1509 L13, 13th-cent. context;
- 67. A SF1300, F1030 L1143, 15th-cent. context;
- 68. A SF2187, F2517 L1, 12th-cent. context.

IRON OBJECTS

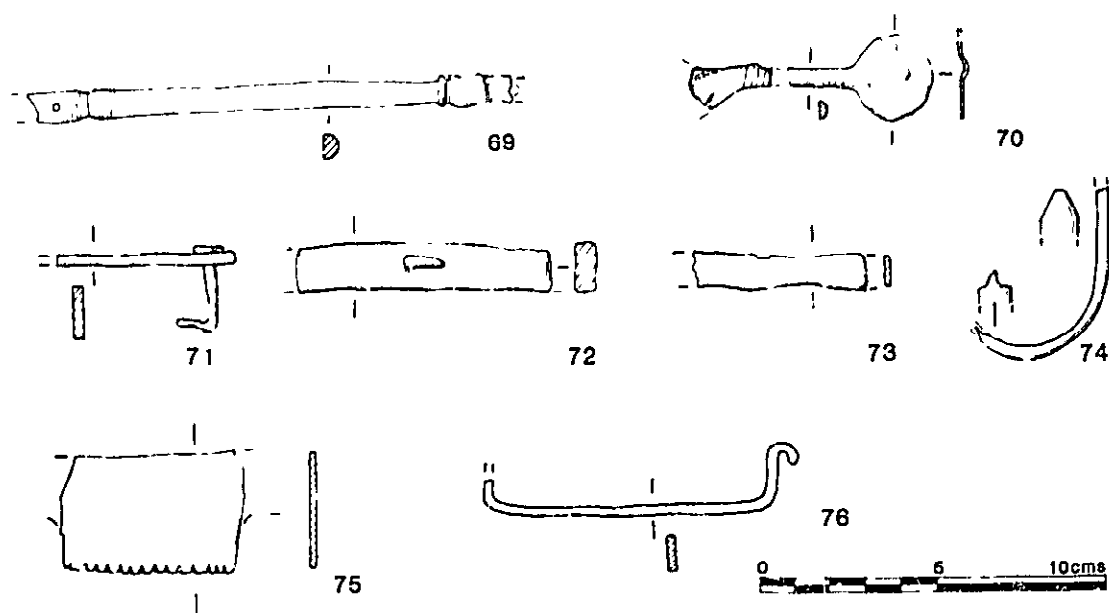

Fig.127

69-74. Binding strip. Nos.69-70 are moulded, plated with non-ferrous metal, and probably from caskets; the remainder are plain.

69. A SF1235, F1522 L3, 11th-cent. context;

70. A SF521, F113 L193, 13th-cent. context;

71. A SF2197, F2522 L1, 13th-cent. context;

72. A SF673, F151 L334, 11th-cent. context;

73. A SF664, F97 L139, 13th-cent. context;

74. A SF671, F140 L305, 13th-cent. context.

75. Object with a shaped edge and non-ferrous plating.

A SF667, F107 L174, 15th-cent. context.

76. Handle.

A SF1199, F1515 L2, 12th-cent. context.

IRON OBJECTS

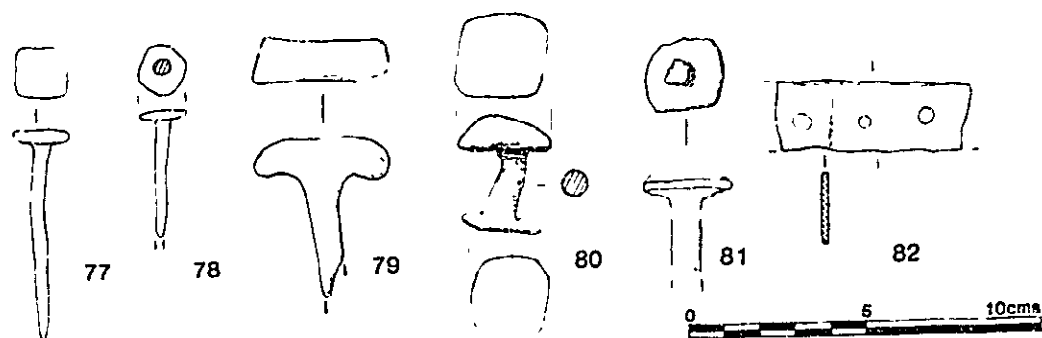

Fig.128

- 77-78. Nails, typical of those found.
A SF1163, F1538, 12th-cent. context.
79. Stud.
A SF2129, F2522, 13th-cent. context.
80-81. Clench belts. No.81 is incomplete.
80. A SF136, L135C, undated context;
81. A SF160, L135, undated context.
82. Strip of flat roves awaiting separation.
A SF1268, F1019 L1102, 14th-cent. context.

IRON OBJECTS

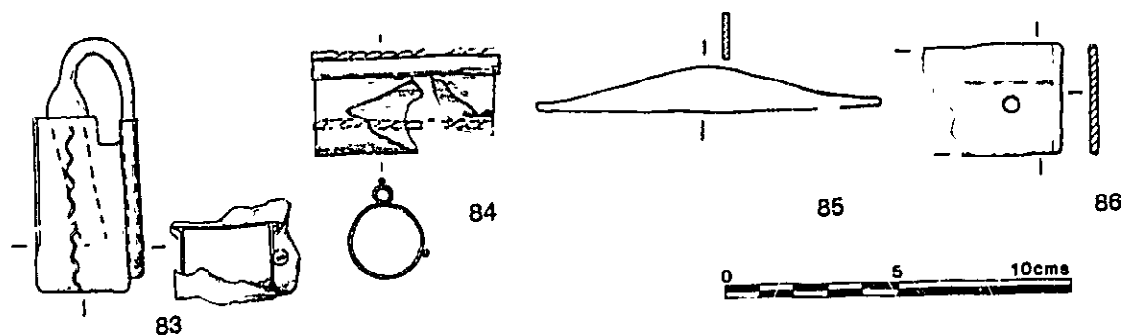

Fig.129

83-95. Locks and keys:

83. Box padlock with damaged case and distorted bolt. The case is plain but for two sinuous wire trails, one incomplete, down two opposing sides. A tube down the outer face of another side houses the free arm of the U-shaped padlock bolt which has a thickened head immediately above the entry plate and probably just a single spine with double-leaf spring. The keyhole was probably in the side opposite that with the tube, but the case is incomplete here. This padlock is a fine, late example of a type principally of 9th to early 11th-century date which was supplanted after the 11th century by one or other form of barrel padlock.

75.25.106 A SF585, F119 L219, 11th-cent. context.

84. Barrel padlock case, damaged, with a tube for the free arm of the padlock bolt attached directly to a plain cylinder strengthened by longitudinal iron rods.

A SF143, L135, undated context.

85. Pivoting fin from a barrel padlock similar to that from Site SEL (Selfridges), Cat. No.135.

A SF1252, F1522 L1, 11th-cent. context.

86. Fin with decorative hole from a barrel padlock. Typologically medieval, and so residual, it is from a padlock similar to that from King's Lynn, Norfolk. [1]

A SF637, F17 L15, mid to late 17th-cent. context.

1. I. H. Goodall in H. Clarke and A. Carter, Excavations in King's Lynn, 1963-1970, Society for Medieval Archaeology Monograph Series, No.7 (1977), 291, Fig.132, No.1.

IRON OBJECTS

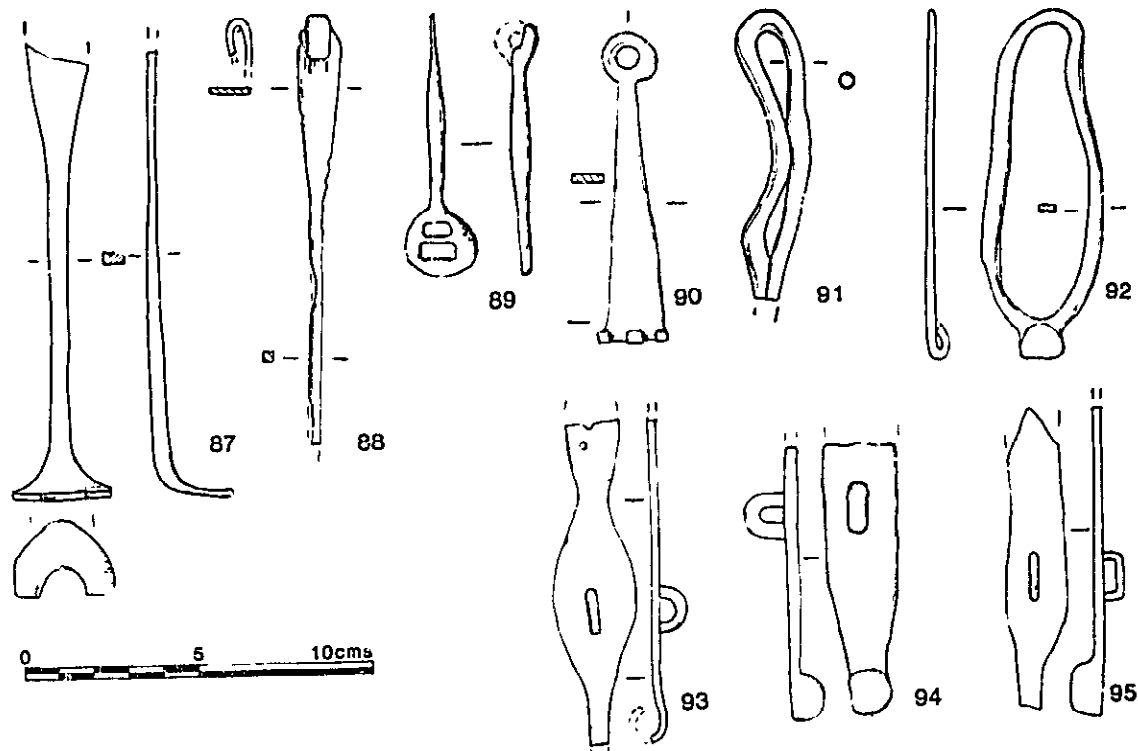

Fig.130

87-90. Padlock keys.

Nos.87 and 88 have, or had, laterally-set bits and stems with expanded terminals, that of No.88 retaining much of its rear hook. Nos.89 and 90 have ring bows, the bit in line with the swollen stem of No.89 but projecting from two sides of the base of the expanding stem of No.90.

87. 75.25.107 A SF1218, F1519 L3, 11th-cent. context;

88. A SF1303, F1035 L1252, 13th-cent. context;

89. A SF240, L140, undated context;

90. A SF1305, F1037 L1068, 14th-cent. context.

91-92. Hasps.

91. A SF131, L135/3, undated context;

92. A SF2090, F2510 L3, 14th-cent. context.

93-95. Stapled hasps for use with locks on chests, etc.

93. 75.25.108 A SF593, F116 L1, 13th-cent. context;

94. A SF3037, F1511 L1, 13th-cent. context;

95. A SF1315, L2041, undated context.

IRON OBJECTS

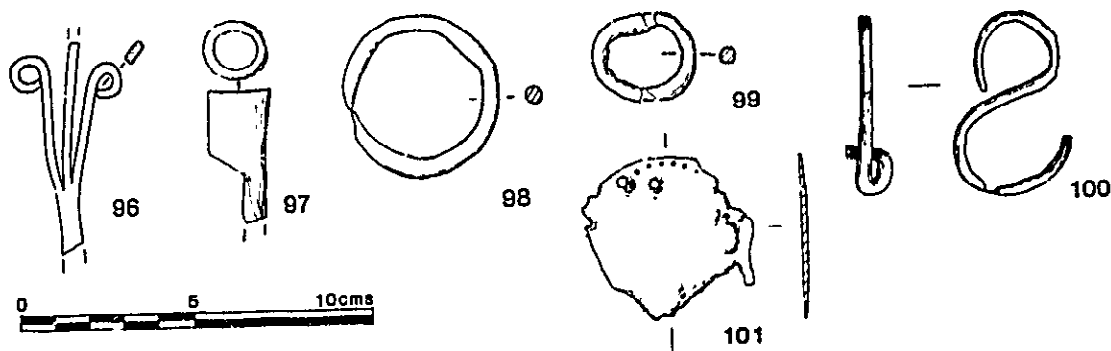

Fig.131

96-101. Household Ironwork:

96. Pricket candlestick with decorative side scrolls. Pricket and stem both broken.
A SF2188, F2541 L1, 13th-cent. context.
97. Socketed candleholder, stem broken.
A SF536, F121 L235, 14th-cent. context.
- 98-99. Rings.
98. A SF1145, F1016 L1121, 13th-cent. context.
99. A SF1020, F1037 L1068, 14th-cent. context.
100. S-hook.
A SF2103, L2 (2M, 102/996), unstratified.
101. Disc with holes close to the rim and within sheet.
Non-ferrous plating.
A SF192, F53 L53, 15th-cent. context.

IRON OBJECTS

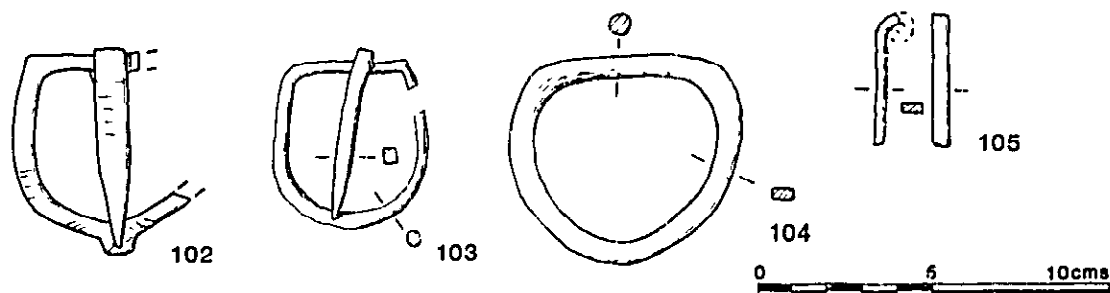

Fig.132

102-105. Buckles:

102-104. D-shaped buckles with non-ferrous plating. No.102 has decorative grooves on both frame and pin; Nos.103 - 104 are plain.

102. A SF2127, F2522, 13th-cent. context;

103. A SF531, F118 L218, 14th-cent. context;

104. A SF1301, F1030 L1143, 15th-cent. context.

105. Buckle pin.

A SF152, F84 L9, 11th-cent. context.

IRON OBJECTS

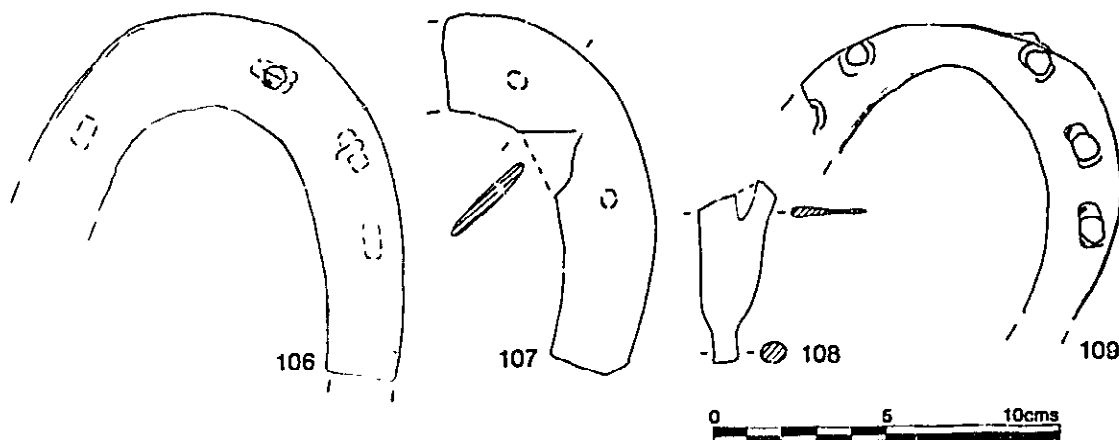

Fig. 133

106-137. Horse and Riding Equipment, Spur by Blanche Ellis:

106-129. Horseshoes, Nos. 106-121 with countersunk nailholes, some with marked wavy edges, Nos. 122-129 with plain nailholes. No. 128 is intrusive.

106. A SF129, L135, undated context;

107. A SF1192, F1556, 11th-cent. context;

108. A SF1212, F1520 L2, 11th-cent. context;

109. 75.25.109 A SF1162, F1053 L1270, 12th-cent. context;

IRON OBJECTS

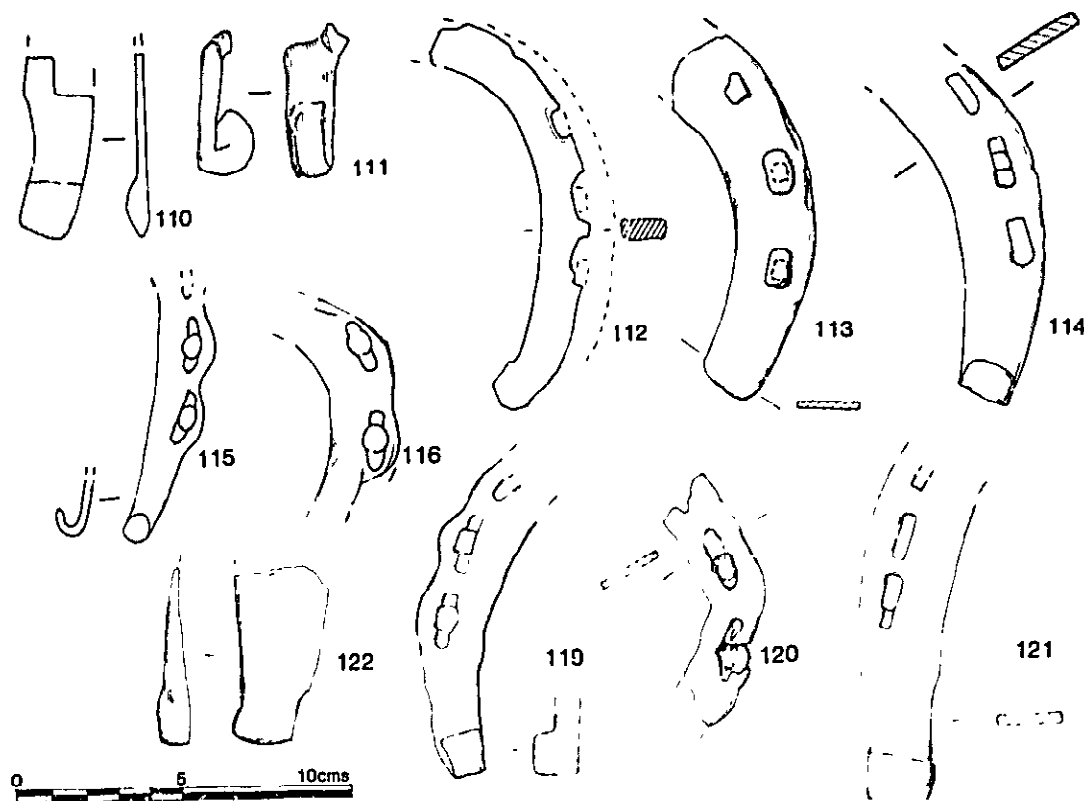

Fig. 134

- 110. A SF3084, L1080, undated context;
- 111. A SF1311, F2505 L1, 12th-cent. context;
- 112. A SF1161, F1540, 13th-cent. context;
- 113. A SF571, F116 L2, 13th-cent. context;
- 114. A SF616, F501, 13th-cent. context;
- 115. A SF1296, F1024 L1245, 13th-cent. context;
- 116. A SF669, F113 L189, 13th-cent. context;
- 117. A SF785, F101 (L78), 13th-cent. context, not illustrated;
- 118. A SF577, F157 L336, 13th-cent. context, not illustrated;
- 119. A SF1369, F2504, late 16th-cent. context;
- 120. A SF1078, L2 (2M, 104/998), unstratified;
- 121. A SF124, L2 (2M, 116/1016), unstratified;
- 122. A SF536, F121 L235, 14th-cent. context;

IRON OBJECTS

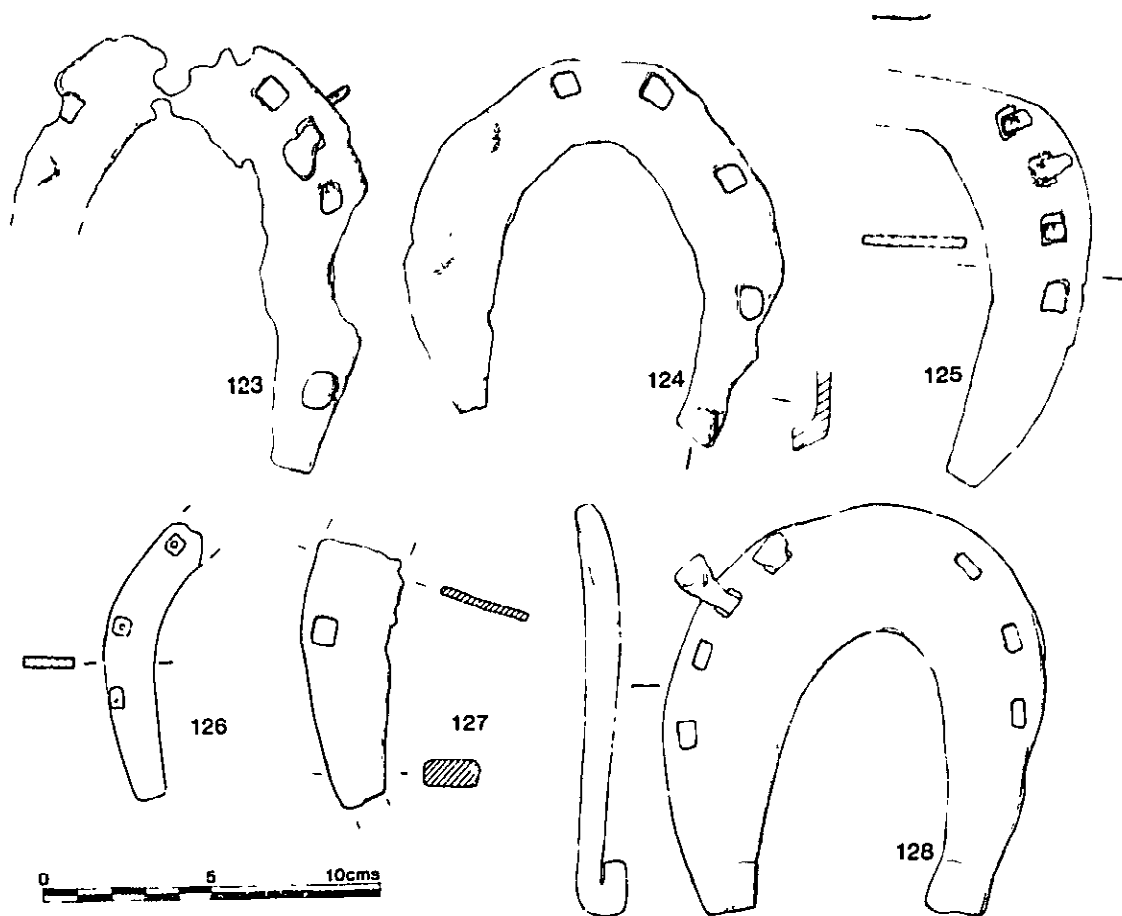

Fig.135

123. A SF1053, F1014 L1090, 15th-cent. context;
 124. A SF1034, F1006 L1062, 15th-cent. context;
 125. A SF1157, F1030A L1143, 15th-cent. context;
 126. A SF1290, F1030 L1219, 15th-cent. context;
 127. A SF1298, F1030 L1219, 15th-cent. context;
 128. 75.25.110 A SF3012, F1501 L1, 11th-cent. context;
 129. A SF3331A, L2013, undated context, not illustrated;

IRON OBJECTS

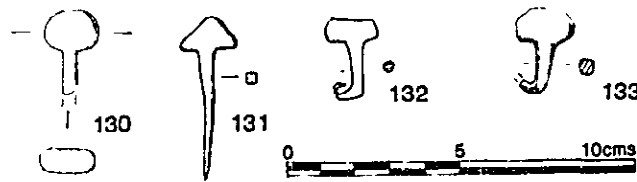

Fig.136

130-133. Fiddle key horseshoe nails from horseshoes similar to Nos.106-121.

- 130. A SF239, L130, undated context;
- 131. A SF2089, F2503 L1, 12th-cent. context;
- 132. A SF1243, F1531 L1, 13th-cent. context;
- 133. A SF6A, L17, undated context.

IRON OBJECTS

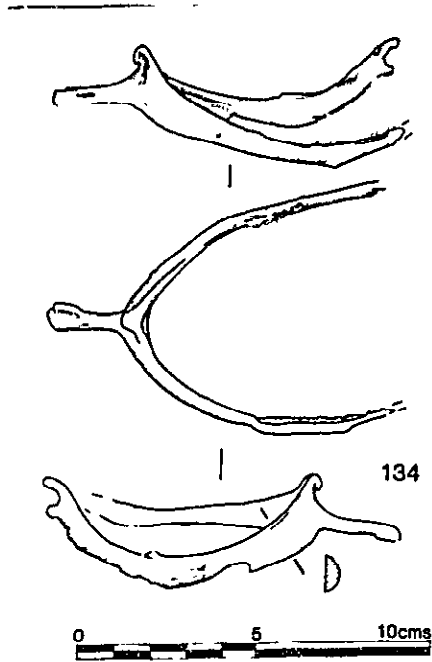

Fig.137

IRON OBJECTS

134. Spur. Blanche Ellis writes: Iron spur, very severely rusted. The sides, now reduced by surface flaking, appear to have been of D-section, curving only slightly under the wearer's ankle but with strongly upward-curving front ends. Part of one terminal ring remains, the other is missing. Above the junction of the sides their top edge is drawn up into a crest which curled over the neck and, although now crushed, it has the remains of a small knobbed tip. The core of part of a straight neck remains, its outer surfaces and end are rusted away.

Overall length c.95mm. Length of neck stump 23mm.

Typologically English c.1400.

Despite its reduction by rusting, the spur appears to belong to a group of rowel spurs whose popularity is known from their having been found at numerous British sites including Pleshey Castle, Essex, [1] Goltho medieval village, Lincolnshire, [2] and from the drainage of Salisbury, Wiltshire; [3] all these examples are iron. The type is depicted on several contemporary monumental brasses including that of Sir Nicholas Dagworth, 1401, in Blickling Church, Norfolk. [4] The spurs have curved sides, curled crests with knobbed tips and usually single-ring terminals. The broken terminal ring remaining on this spur from Oxford is incomplete, but it is large enough to have been a single ring terminal.

75.25.111 A SF1087, L2 (2N, 104/1002), unstratified.

1. B.M.A. Ellis 'The Spurs', in F. Williams, Excavations at Pleshey Castle, B.A.R. British Series, 42 (1977), 180-82, Fig.40, No.46.
2. B.M.A. Ellis in G. Beresford, The Medieval Clay-Land Village: Excavations at Goltho and Barton Blount. Society for Medieval Archaeology Monograph No.6 (1975), 89-90, Fig.42, Nos.131-32.
3. Salisbury Museum iiB12 in the Drainage Collection; new Medieval Catalogue (in prep.) No.20.
4. Ibid., Beresford, 90, Fig.42.

IRON OBJECTS

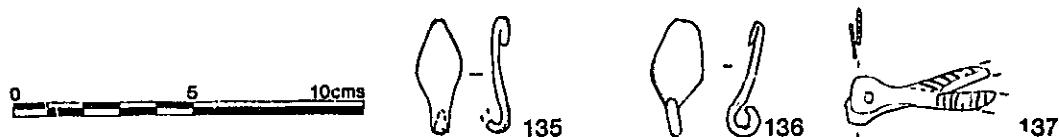

Fig.138

135-136. Hook attachments from spurs.
A SF3331C & D, L2013, undated context.

137. Incomplete strap loop with incised decoration retaining non-ferrous plating.

75.25.112 A SF1207, F1515 L3, 12th-cent. context.

IRON OBJECTS

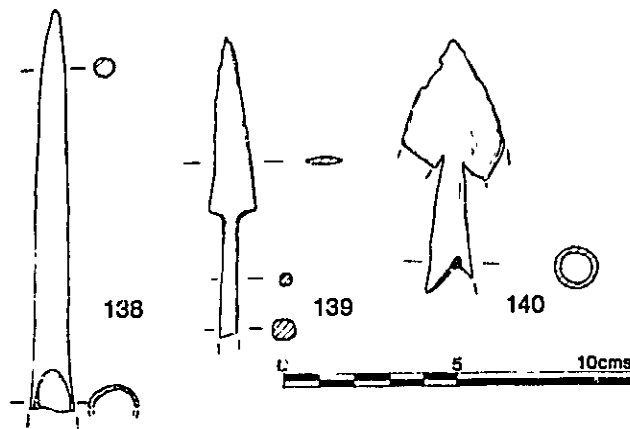

Fig. 139

138-140. Weapons:

138. Spearhead with broken socket, similar to some from London.
[1]
75.25.113 A SF541, F115 L203, 13th-cent. context.
139-140. Socketed arrowheads.
139. 75.25.114 A SF1083, L2 (2M, 104/1014), unstratified;
140. A SF1070, L2 (2M, 110/994), unstratified.

1. London Museum Medieval Catalogue, (1954), 73-74, Pl.XVI, Nos.1-4.

IRON OBJECTS

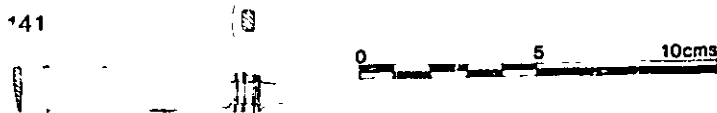

Fig.140

Site B, Greyfriars

141-142. Knives, both residual. No.141 has a broken blade and whittle tang, the latter with two pairs of rectangular iron plates which were originally interleaved with organic pieces to form a decorative handle. For a comparison see knives from Brooklands, Surrey, and elsewhere. [1] No.142 (not illustrated) has the stub of a whittle tang and a broken blade whose back and cutting edge taper equally towards the tip.

141. 75.27.15 B IX SF3, F2, early 17th-cent. context;
142. B XXXIII SF4, F19, early 17th-cent. context.

1.

I. H. Goodall 'Medieval Iron Objects' in R. Hanworth & D.J. Tonalin, Brooklands, Weybridge: The Excavation of an Iron Age and Medieval Site 1964-65 and 1970-71, (Surrey Archaeological Society Research Volume No.4, Guildford, 1977), 73, Fig.45, No.4.

IRON OBJECTS

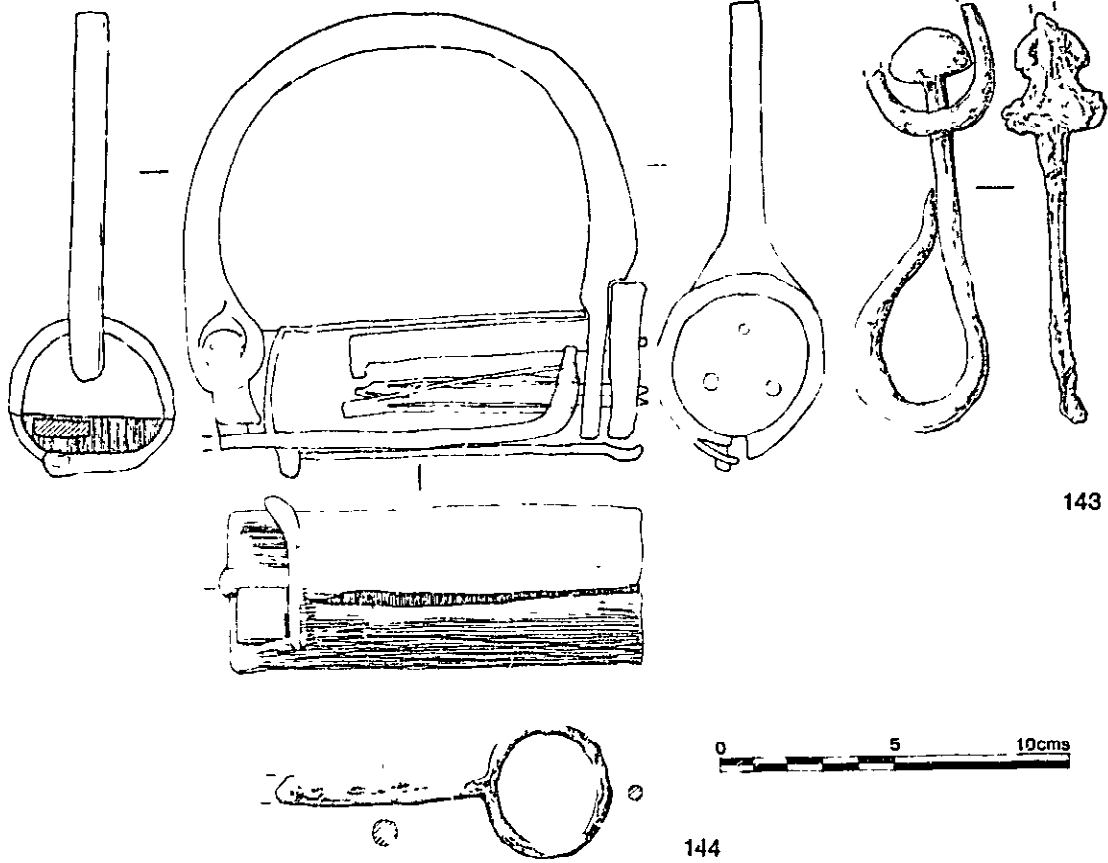

Fig. 141

M. III E1

IRON OBJECTS

143. Leg shackle. The surviving components are a barrel padlock with shackle found with a human legbone through it, a link fragment (not illustrated) and a swivel loop. The padlock, which has a plain case and traces of non-ferrous plating, was buried complete with its bolt and key although only that part of the key within the case now survives. The bolt has two spines each with a double leaf spring and an additional bar above implying a padlock key bit similar to that of a key from Upton, Gloucestershire. [1] The link, too fragmentary to record, but apparently oval in shape, and the swivel ring and loop, must have formed part of a chain attached to the padlock and the whole may be compared with a similar object from Coventry. [2]
- Human burials with shackles are not completely unknown. Excavations within the cathedral at Old Sarum located a skeleton 'deposited with a wonderfully perfect set of leg-irons'. These leg-irons consist of three links joining two end rings which are closed and forged shut, and capable of release only by a blacksmith. [3] Their permanent form contrasts, therefore, with the flexibility of the Greyfriars, Oxford, leg shackles.
- 75.27.17 B IV SF18, F41, undated context (burial).
144. Key bow and broken stem.
- 75.27.16 B IX SF1, F1, Phase V context.

-
1. R.I. Hilton & P.A. Rahtz, 'Upton, Gloucestershire, 1959-1964', Transactions of the Bristol and Gloucestershire Archaeological Society, lxxxv (1966), 120, Fig.13, No.2.
 2. P.B. Chatwin, 'Recent Finds in Coventry', Transactions and Proceedings of the Birmingham Archaeological Society, lviii (1934), 58, Pl.XIV, Fig.1.
 3. W.H. St.John Hope, 'Report on the Excavation of the Cathedral Church of Old Sarum in 1913', Proceedings of the Society of Antiquaries of London, xxvi (1914), 116; Salisbury Museum Acc. No. O.S.C.55.

IRON OBJECTS

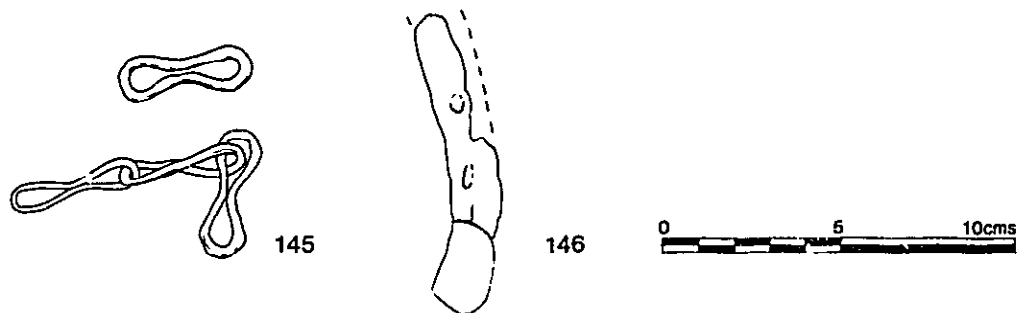

Fig.142

145. Chain of three figure-eight links.
B II SF11, F11, undated context (burial).
146. Horseshoe arm of early medieval date with calkin and corroded-out countersunk nailholes. Residual.
B IV SF66, F13 L1, mid to late 17th-cent. context.

IRON OBJECTS

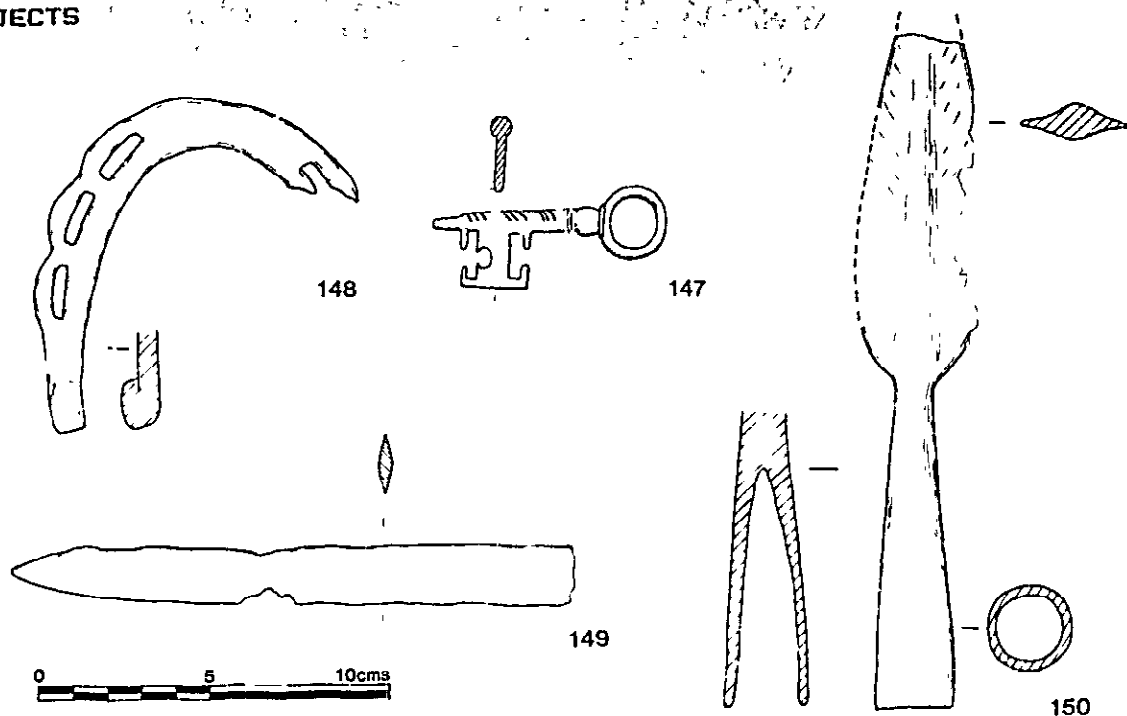

Fig.143

Site D. Littlegate

147. Key with ring bow, moulded stem decorated with incised diagonal grooves and plated with non-ferrous metal.
75.33.3 D I SF38, L37, late 13th- to early 14th-cent. context.
148. Horseshoe, one arm broken, the other with countersunk nailholes, wavy edge and calkin.
D I SF16, L15, late 12th- to mid 13th-cent. context.
149. Fragment of a narrow double-edged dagger blade.
D IV SF67, F120, undated context.
150. Socketed spearhead with a slender, incomplete leaf-shaped blade comparable with examples from London. [1]
75.33.4 D I SF42, F50, late 12th- to early 13th-cent. context.

1. London Museum Medieval Catalogue (1967 repr.), 74, Pl.XVI.5.

IRON OBJECTS

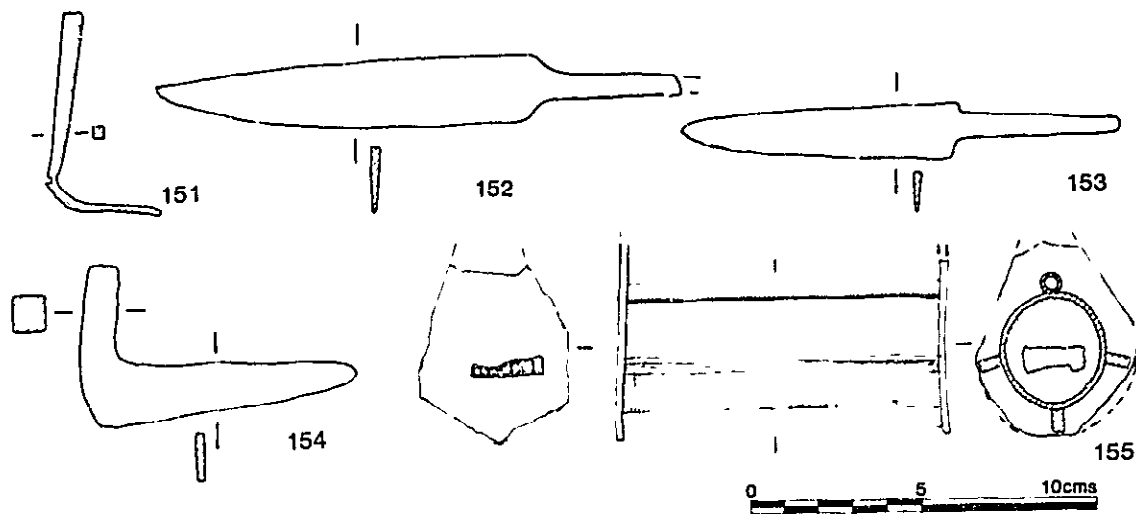

Fig.144

Site SEL, Selfridges

- 151. Distorted heckle tooth.
SEL SF20, F55, 12th-cent. context.
- 152-153. Whittle tang knives.
152. SEL SF1, F1, 10th- to 11th-cent. context.
153. 75.35.4 SEL SF22, F67, 12th-cent. context.
- 154. Hinge pivot.
SEL SF10, F23, 12th- to 13th-cent. context.
- 155. Barrel padlock case, heavily corroded but evidently with a plain case between end plates linked by a tube for the bolt and perhaps three pivoting fins. A similar padlock comes from Christchurch, Hampshire. [1]
75.35.5 SEL SF16, F46, 13th-cent. context.

1. Illustrated in I. H. Goodall, 'The Medieval Blacksmith and his Products', in D.W. Crossley (ed.), Medieval Industry, C.B.A. Research Report No.40 (1981), 60, Fig.57, No.2.

IRON OBJECTS

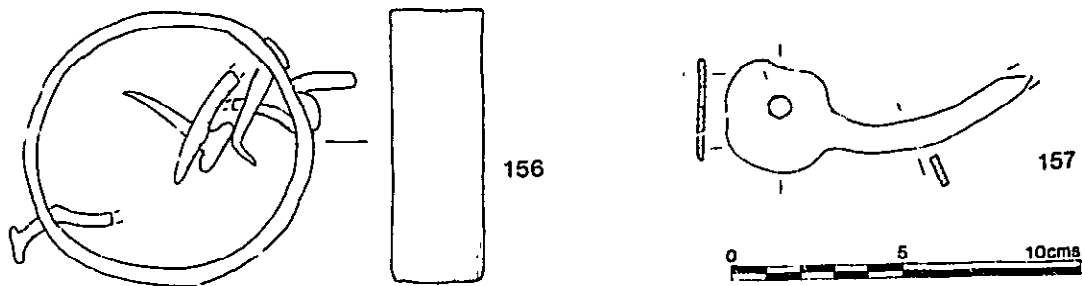

Fig.145

156. Collar.
75.35.6 SEL SF21, F57, late 11th-cent. context.
157. Terminal from a currycomb, not unlike a more complete example from the Hamel, Oxford. [1]
75.35.7 SEL SF18, F50, undated context.

1. I. H. Goodall in N. Palmer, 'A Beaker Burial and Medieval Tenements in the Hamel, Oxford', Oxoniensia, xlv (1980), Fig.31, No.67; M II C09.

IRON OBJECTS

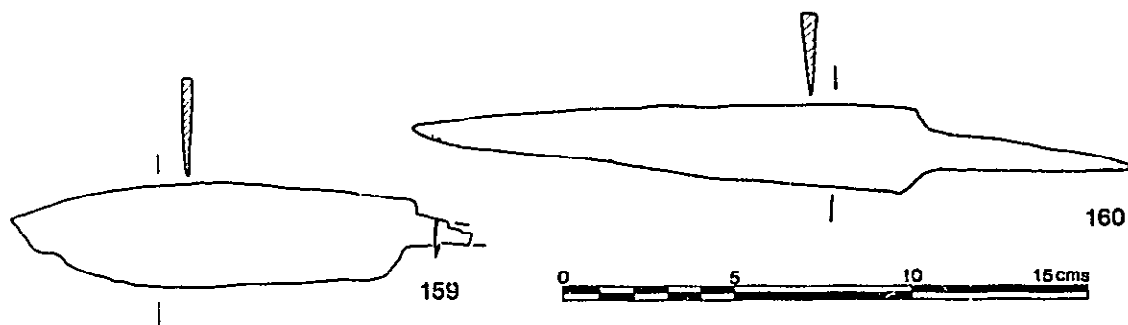

Fig.146

Site W, Westgate

158. Whittle tang, length 95mm. Not illustrated.
W SF70, F50 L5/1, 11th-cent. context.
- 159-160. Whittle tang knives, No.160 with a non-ferrous plate on the tang.
No.160 was incorrectly published as coming from the Barbican Ditch. [1]
159. W SF73, F34, 12th-cent. context;1
160. 75.26.1 W SF3, F59, undated context.

1. I. H. Goodall in T.G. Hassall, 'Excavations at Oxford Castle, 1965-73', Oxoniensia, xli (1976), 297, Fig.26, No.2.

Site A, 31-34 CHURCH STREET

SLAG by C.J. SALTER [1]

This report was produced in 1979 and does not take account of subsequent research.

The samples are sorted into three groups:

Group 1

Samples associated with copper working.

A SF95, F99 L167, 11th-cent. context;

A SF2174, F2520 L1, 12th-cent. context Crucible with traces of copper alloy on the surface.

Very clear evidence of molten copper alloys.

(con.)

-
1. Department of Metallurgy and Science of Materials,
University of Oxford, Parks Road, Oxford, OX1 3PH.

SLAG

Group 2

Samples clearly associated with some form of iron working.

- A SF142, L2, unstratified;
- A SF185, F86 L146, 14th-cent. context;
- A SF619, F512, 10th-cent. or earlier context;
- A SF1169, F1515 L3, 12th-cent. context;
- A SF1191, F1556, 11th-cent. context;
- A SF2154, F19 L2022, post-medieval context;
- A SF3057, F1019 L1102, 14th-cent. context;
- A SF3058, F1028 L1080, 12th-cent. context;
- A SF3113, L135, undated context;
- A SF3114, L354, undated context.

These samples consist of three main mineral components: olivine, iron oxide and a glassy phase with a near anorthitic composition. There can also be present a number of minor components depending on the amount of earthy material dissolved in the slag, together with small inclusions of metallic iron.

The process by which slags of such composition could be formed are either in the smelting process, or during the smithing stage of the manufacturing process. It is, however, very difficult to distinguish the slags from either of these processes, although research into this is being carried out in both Aston and Oxford Universities' Metallurgy Departments. It is hoped that in a year the problem will have been solved. [1]

In the meantime, the high iron oxide content in some of the slag samples from Church Street suggests that a smithing process was the source of the slags, a conclusion further supported by the lack of any samples showing flow features indicating tap slags.

1. This report was produced in 1979.

SLAG

Group 3

Samples probably associated with iron working but which have structures and compositions differing from those of typical iron working slags.

- A SF153, F84 L9, 11th-cent. context;
- A SF553, F145 L317, 13th-cent. context;
- A SF1209, F1515 L3, 12th-cent. context;
- A SF2081, F2513 L1, 14th-cent. context;
- A SF2096, F2520 L1, 12th-cent. context;
- A SF2106, L2038, undated context;
- A SF2181, F2505, 12th-cent. context;
- A SF3028, F1503 L1, 11th-cent. context;
- A SF3039, F1006 L1053, 15th-cent. context;
- A SF3112, F202 L2, feature no. not traced. F2002? F502?

This group of slags is closely related to Group 2 and represents iron working slags contaminated with extraneous material. This contaminant material being either of a calcitic or clayey calcitic nature, if there were sufficient clay to bind the local calcitic sands the mixture could have been used to line the furnace. The result of the reaction between an iron slag and such a lining material is similar to that seen in the Group 3 slags if the reaction was terminated before completion. Similar results would have been produced by the reaction of a slag and a calcite tempered crucible. [1]

1. See the Pottery Report, F116. Fig.47, Nos.10-11.

SLAG

A SHORT DESCRIPTION OF THE SLAGS

A SF95, F99 L167, 11th-cent. context

A crystalline slag containing 2-5% magnetite and globules of metallic copper in an olivine matrix. The nature of this slag suggests that it was produced in a copper working process.

A SF142, L2, unstratified

A mainly crystalline slag containing olivine laths in a matrix of 'anorthitic' material and the iron oxide wustite together with a little metallic iron.

A SF153, F84 L9, 11th-cent. context

A glassy slag containing included grains of calcite and quartz which have not completely reacted with the slag.

A SF185, F86 L146, 14th-cent. context

A larger piece of slag with a basically olivine anorthite composition but with varying amounts of free iron and iron oxides. In some sections the free iron content becomes very high (up to 10%). This could point to the hypothesis that crude blooms were being forged rather than the forging of finished metal.

A SF553, F145 L317, 13th-cent. context

A glassy slag reacting with calcite grains.

A SF619, F512, 10th-cent. or earlier context

A typical iron working slag.

A SF1169, F1515 L3, 12th-cent. context

A slag with a very high iron oxide content suggesting it has formed by the slagging of iron scale produced during smithing.

SLAG

A SF1191, F1556, 11th-cent. context

An iron working-type slag with charcoal impressions on the surface. The slag also contains silica rich inclusions.

A SF1209, F1515 L3, 12th-cent. context

A mainly glassy slag reacting with calcareous material.

A SF2081, F2513 L1, 14th-cent. context

A glassy slag with a low iron content.

A SF2096, F2520 L1, 12th-cent. context

A large fragment of slag showing reaction with a clayey material, which is very likely to represent the furnace lining.

A SF2106, L2038, undated context

Glassy slag produced by the reaction with a sandy calcareous material.

A SF2154, F19 L2022, post-medieval context

An inhomogeneous slag, containing charcoal impressions. A little free metallic iron was present together with much iron oxide, not a free running slag.

A SF2174, F2520 L1, 12th-cent. context

A thin coat of glassy material on the concave surface of a ceramic object. There was a small splash of copper on the edge together with red copper oxide.

A SF2181, F2505, 12th-cent. context

A slag containing magnetite and areas of massive iron oxides in a basically glassy matrix. An iron working product.

A SF3028, F1503 L1, 11th-cent. context

A glassy material with occasional polyhedral crystals, indicating a high aluminium content.



SLAG

A SF3039, F1006 L1053, 15th-cent. context

A mixture of glass and very fine crystalline material, probably formed by the reaction of a slag with a clayey material.

A SF3057, F1019 L1102, 14th-cent. context

A dense slag containing iron oxides in a matrix of olivines and glass together with a little free iron. An iron working product.

A SF3058, F1028 L1080, 12th-cent. context

A slag similar to A SF3057 but with a lower iron oxide content but still with a similar amount of free iron.

A SF3112, F202 L2, feature no. not traced. F2002? F502?

A highly vesicular glassy material of a light green colour.

A SF3113, L135, undated context

This slag sample contained two quite distinct regions: one with a rusty red colour, and the other with a more normal slag appearance. The first area consists of a limonite-hematite ground mass enclosing crystals of quartz and calcite. In the second area there are varying amounts of iron oxides in a glassy matrix. Although the first area could represent a reasonable ore there is no sign of reduction occurring even though the sample has been subjected to considerable heat.

A SF3114, L354, undated context

A slag similar to A SF3057, an iron working slag.

SLAG

Slag, no reports:

Site B, Greyfriars

- B IV SF42, F62 L2, early 13th-cent. context?
- B IV SF71, F13, mid to late 17th-cent. context.
- B IV SF74, F49, mid to late 17th-cent. context.

Site W, Westgate

- W SF59, F89, 13th- to 14th-cent. context.
- W SF60, F97, 11th- to 12th-cent. context.
- W SF72, F50 L6/3, 11th-cent. context.
- W SF78, F56, late 11th-cent. context.
- W SF79, F89, contains part of objects W SF58 & W SF59 (unidentifiable copper alloy objects), 13th- to 14th-cent. context.
- W SF86, F23, 13th- to 14th-cent. context.
- W SF91, F52, 12th-cent. context.
- W SF93, F50 L6, 11th-cent. context.

Clinker, no report:

Site B, Greyfriars

- B IV SF77, F49, mid to late 17th-cent. context.

BONE, IVORY AND ANTLER OBJECTS by GEOFF EGAN AND MARTIN HENIG
MATERIAL IDENTIFICATION by PHILIP ARMITAGE AND BOB WILSON

Figs. 147-167

Site A: 1-64; Site B: 65-66; Site D: 67-69.

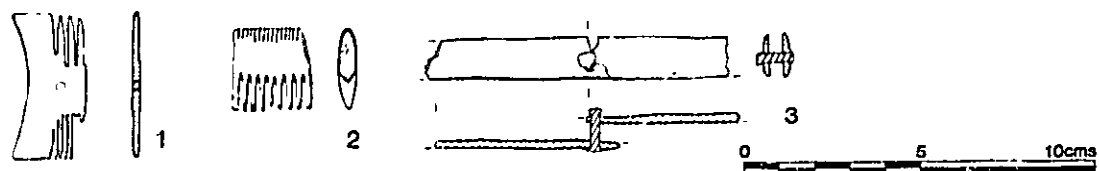

Fig. 147

Site A, 31-34 Church St. by Geoff Egan [1]

This report was written in 1978 and does not take account of subsequent research.

1-8. Comb Fragments: [2]

Double-sided types, all with fine and coarse teeth on opposite sides unless stated.

1. Bone end tooth segment. Concave-end, with tooth graduat: n. A rusted rivet hole for attaching a connecting plate indicates that it is part of a complex comb.

75.25.115 A SF7A, Trial Trench, unstratified.

2. Bone fragment possibly reused as a single-sided comb since the fine teeth have been neatly cut off at the edge of the solid zone.

75.25.116 A SF2057, F2502 L3, 14th-cent. context.

3. Bone connecting plates with iron rivets. No cut marks from tooth-cutting are visible.

75.25.117 A SF159, L135, undated context.

1. I am grateful to Dr. M. Henig for his preliminary notes on Nos. 13 & 22-27 which indicated the parallels cited.

2. The terminology used here for combs follows P. Galloway, 'A Note on the Description of Bone and Antler Combs', Medieval Archaeology, xx (1976), 154-56.

BONE, IVORY AND ANTLER OBJECTS

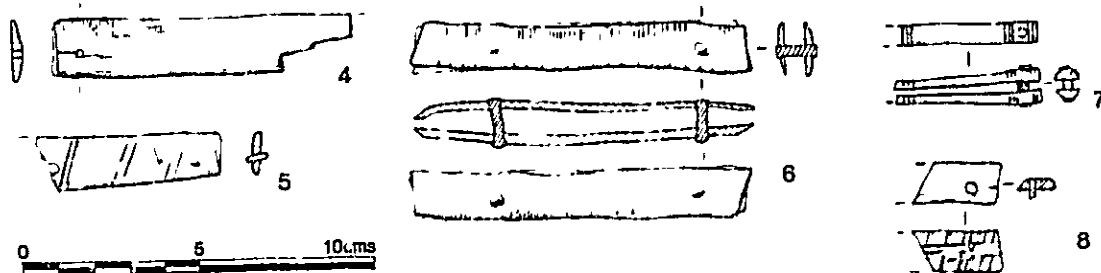

Fig.148

4. Bone connecting plates marked from the cutting of fine teeth. A similar object was found in a pit in the pre-bailey bank at Oxford Castle. [1]

75.25.118 A SF162, L135, undated context.

5. Bone comb connecting plates decorated with incised lines and grooves. From a single-sided composite comb with iron rivets. [2]

75.25.119 A SF1127, F1503 L2, 11th-cent. context.

6. Bone connecting plates with iron rivets from a double-sided comb. Marked on all four edges from the cutting of fine and coarse teeth.

75.25.120 A SF64, F73 L92, undated context.

7. Pair of antler connecting plates with an iron rivet and incised lines. Possibly from a comb.

75.25.121 A SF3317, F501, 13th-cent. context.

8. Plain, antler (?) strip. Possibly a comb connection plate.

75.25.122 A SF3333, F1006 L1054, 15th-cent. context.

1. T.G. Hassall, 'Excavations at Oxford Castle, 1965-73', Oxoniensia, xli (1976), 298-99; Fig.26, No.3. The object is called a probable comb case.
2. Cf. B. Durham, 'Archaeological Investigations in St. Aldates, Oxford', Oxoniensia, xliii (1978), Fig.38, No.11.

BONE, IVORY AND ANTLER OBJECTS

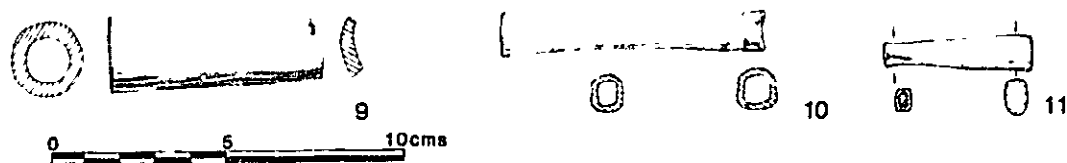

Fig.149

9-15. Knife etc. Handles:

Latho-cut centrally to accept a whittle tang:

9. External and internal turning marks. Bone.

75.25.123 A SF1037, F1013 L1088, 14th-cent. context.

10. Probably knife trimmed externally. Surface highly polished. Bone, caprovine metatarsus. Possibly a burnisher or thread reel rather than a handle.

75.25.124 A SF125, L135/8, undated context.

Whittle-tang tool:

11. Short, tapered bone handle with an iron tang.

75.25.125 A SF3318, F501, 13th-cent. context.

BONE, IVORY AND ANTLER OBJECTS

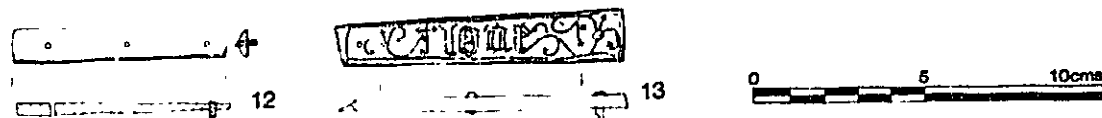

Fig.150

12-15. Scales for fixing to a central metal strip extending back from a blade:

12. Scale of bone or ivory with a copper or alloy rivet.

75.25.126 A SF1056, F1023 L1147, mid 17th-cent. context.

13. Scale decorated with tin [1] dots making foliate motifs and the word LOVE in black letter. Two of the three iron rivets are present. Incised guidelines showing where to put the decoration are visible in places. From a wedding knife or love token. Probably bone.

A more complete handle, with parts of both scales, decorated in the same manner and dated to the 13th century or earlier was found at the medieval village of Seacourt. [2]

Troughs would have been made in the bone and filled with molten metal, the excess being removed by wiping, and the remainder would be allowed to solidify. Alternatively a block of soft metal would be rubbed over the surface to fill the depressions.

75.25.127 A SF1122, L2 (2M, 110/998), unstratified.

See also No. 56 below.

1. Dr. Peter Northover of the Oxford University Department of Metallurgy has identified the metal as tin (pers. comm.).
2. M. Biddle, 'The Deserted Medieval Village of Seacourt, Berkshire', *Oxoniensia*, xxvi/xxvii (1961-62), 172-74, Fig.29, No.4; Pl. XIB.

BONE, IVORY AND ANTLER OBJECTS

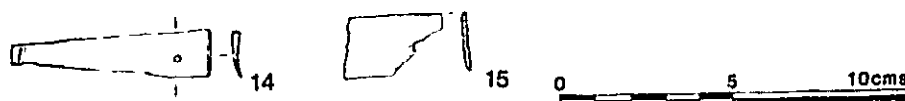

Fig.151

14. Bone (sheep rib) cut, smoothed and pierced, for a knife handle?
75.25.128 A SF3334, F1527 L1, 12th-cent. context.
15. Cut, parallel-sided, flat bone fragment. Polished.
75.25.129 A SF3321, F501, 13th-cent. context.

BONE, IVORY AND ANTLER OBJECTS

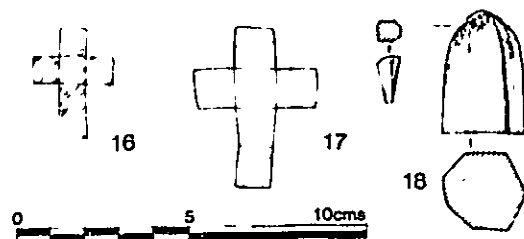

Fig.152

16-18. Gaming Pieces:

16. ?Bone die, double circle and dot numbers.

75.25.130 A SF25, L2 (2M, 116/1014), unstratified.

17. Bone die, cut depressions for numbers.

75.25.131 A SF49, L2 (2M, 114/1002), unstratified.

18. Chessman, probably a pawn. Irregular heptagon with a somewhat rounded top, in which a peg is inserted into an area of cancellous material. Antler, probably from the tine of a red deer. [1]

75.25.132 A SF1095, L2 (2M, 106/1000), unstratified.

1. Cf. O.M. Dalton, British Museum Catalogue of Ivory Carvings of the Christian Era, (1909), 73, No.133; Pl.XLVIII (12th-century example from the Lewis chess set); J.M. Lewis, 'Excavations at Loughnor Castle', Chateau Gaillard VII (1975), 153, Pl.IB; O.M. Dalton, 'Early Chessman of Whale's Bone Excavated in Dorset', Archaeologia, lxxvii (1927), 77; Pl. VI, No.3 (Witchampton, Dorset).

BONE, IVORY AND ANTLER OBJECTS

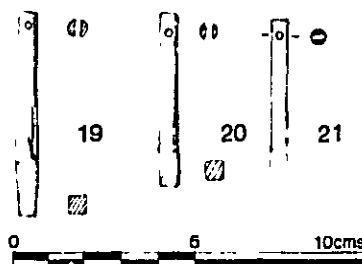

Fig.153

19-21. Tuning Pegs for Strinned Instruments:

19. Bone, tapering string hole.

75.25.133 A SF18, L2 (2M, 112/1014), unstratified.

20. Bone. Pierced, possible wear-marks from strings and polish from use.

75.25.134 A SF1111, L2 (2M, 108/996), unstratified.

21. Bone, end broken off. Pierced.

75.25.135 A SF3310, F53 L53, 15th-cent. context.

Such pegs would be used for instruments with pegboards accessible from both sides i.e. harps, lyres or lutes. There is a full discussion of similar objects, both used and unfinished, from a manufacturing are dated to the 15th century at St. Aldates. [1]

1. B. Durham, 'Investigations in St. Aldates, Oxford', Oxoniensia, xliii (1978), Fig.39, Nos.1-11.

BONE, IVORY AND ANTLER OBJECTS

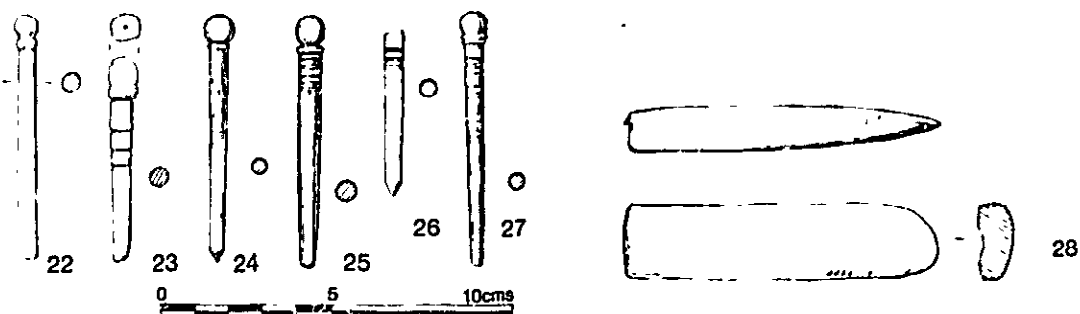

Fig.154

22-27. Manuscript Prickers or Pins:

22. Bone.

75.25.136 A SF68, L2 (2M, 114/1006), unstratified.

23. Bone. End irregular; broken off, but smoothed by subsequent use?

75.25.137 A SF211, L2 (2M, 110/1012), unstratified.

24. Bone with a spherical head and tapering end with traces of an iron pin.

75.25.138 A SF1055, F1023 L1147, mid 17th-cent. context.

25. Bone with an ovoid head, rilled around the upper part of the shaft. Flattened end with traces of a pin.

75.25.139 A SF2082, L2 (2M, 102/1006), unstratified.

26. Bone. Top broken. End crudely cut (or recut) to a point.

75.25.140 A SF2083, L2 (2M, 100/1008), unstratified.

27. Bone with an ovoid head, and three areas of rilling on the shaft. Flat end with traces of a pin.

75.25.141 A SF2102, F2529, 14th-cent. context.

28. (?) Burnisher:

Bone. Possibly a burnisher, perhaps for polishing parchment before it was written on. Cancellous material on one side, cut ridges at the blunt end. Smoothed by prolonged use.

75.25.142 A SF19, L2 (2M, 114/1010), unstratified.

BONE, IVORY AND ANTLER OBJECTS

Nos. 22-27 may be tools used for pricking manuscript sheets. Rigold prefers to interpret objects like these as items use in domestic sewing. [2] Similar objects were found at St. Aldates, in London and in Southampton. [3]

1. Such tools are mentioned in the 12th century by Alexander Neckham, quoted in U.T. Holmes, Daily Living in the Twelfth Century, (Wisconsin, 1952), 69.
2. S.E. Rigold, 'Eynesford Castle and its Excavation'. Archaeologia Cantiana, lxxxvi (1971), 148-49, No.2.
3. B. Durham, 'Archaeological Investigations in St. Aldates, Oxford', Oxoniensia, xlii (1977), Fig.38, No.15; M. Henig in T. Tatton-Brown, 'Excavations at the Customs House Site, City of London, 1973', Transactions of the London and Middlesex Archaeological Society, xxv (1974), 197-98 and Fig.41, Nos.215-18; C. Platt and R. Coleman-Smith, Excavations in Medieval Southampton 1953-1967, (1975), Vol.2 The Finds, 271f, No.192B (13th-century).

BONE, IVORY AND ANTLER OBJECTS

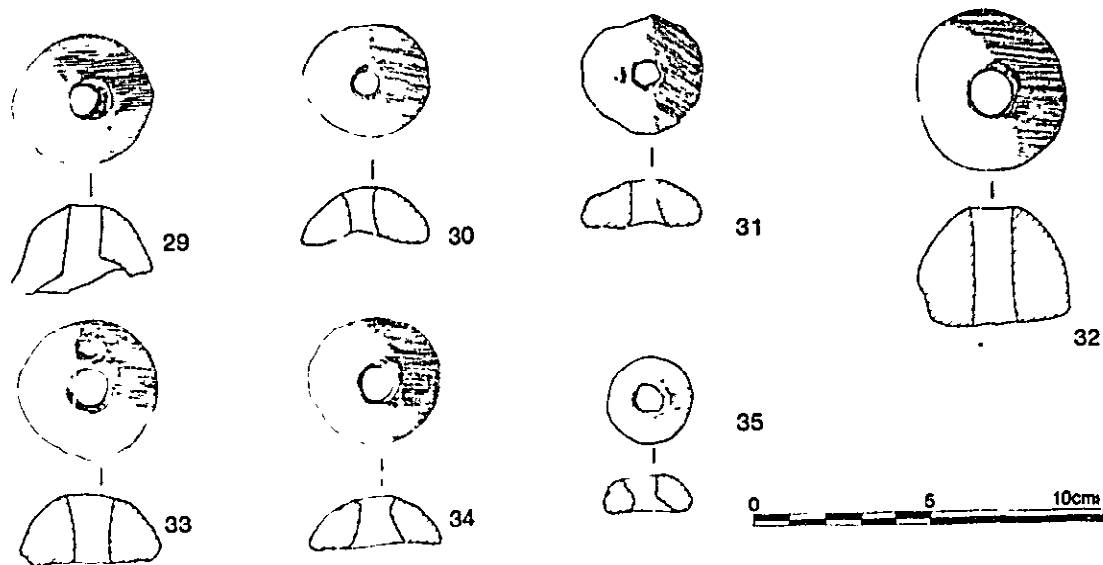

Fig.155

29-35. Spindle Whorls:

All are of bone. The majority are probably made from cattle femur, proximal ends. The holes are rounded unless stated.

29. Upper side trimmed. Weight 13gm.

75.25.143 A SF133, L135/9, undated context.

30. Upper side partly trimmed, hole unrounded. Weight 5gm.

75.25.144 A SF135A, L135/1, undated context.

31. Upper side partly trimmed, worn. Weight 7gm.

75.25.145 A SF135B, L135/1, undated context.

32. Upper side fully trimmed. Weight 25.5gm.

75.25.146 A SF1072, L2 (2M, 104/998), unstratified.

33. Upper side partly trimmed, worn. Weight 11.5gm.

75.25.147 A SF2144, L2 (2M, 104/1016), unstratified.

34. Upper side trimmed flat. Weight 10gm.

75.25.148 A SF1173, F1554, 11th-cent. context.

35. Bone (sheep femur, probably the proximal end).

75.25.149 A SF3311, F94 L88, 13th-cent. context.

The very light examples may have been for spinning fine threads, perhaps for embroidery, or they could be children's toys.

BONE, IVORY AND ANTLER OBJECTS

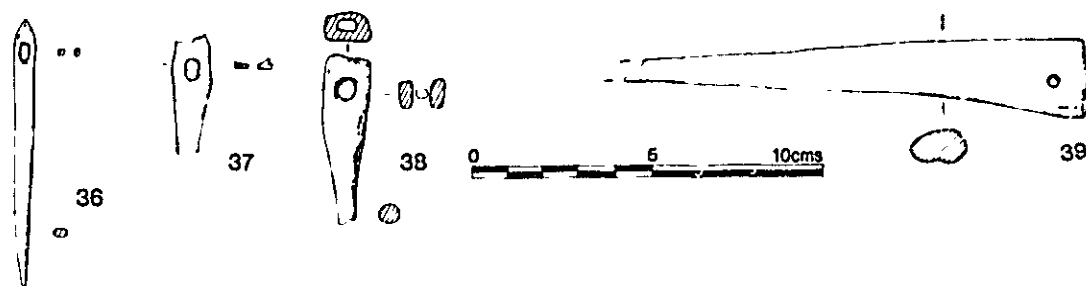

Fig.156

36-39. Needles or Bodkins:

36. Bone. Rectangular eye.

75.25.150 A SF548, F107 L251, 15th-cent. context.

37. Fragmentary; broken at the end. Retains the irregular shape of the bone. A similar fragment was found at St. Aldates [1] and a complete example was found in Southampton [2].

75.25.151 A SF558, L355, undated context.

38. Bone, broken at one end.

75.25.152 A SF2051, F2502 L1, 14th-cent. context.

39. Pierced and pointed bone point (cattle metapodial).

75.25.153 A SF3325, F1031 L1151, 13th-cent. context.

1. Cf. B. Durham, 'Archaeological Investigations in St. Aldates, Oxford', Oxoniensia, xliii (1978), Fig.38, No.12.
2. C. Platt and R. Coleman-Smith, Excavations in Medieval Southampton 1953-1969, (1975) Vol. 2 The Finds, 271-72, No.1929.

BONE, IVORY AND ANTLER OBJECTS

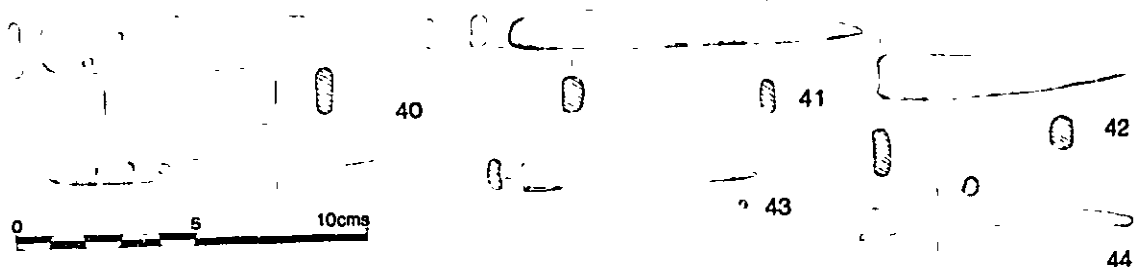

Fig.157

40-42. Pin Beaters (Thread Pickers):

Bones, lacking an eye, of flattish oval section. For a discussion of this type of object see E. Crowfoot. [1]

40. Bone, circle and dot ornament at the wide end, worn. c. 13th-century. [2]

75.25.154 A SF3A, Trial Trench L15, undated context.

41. Bone, with grooved wear marks on one face.

75.25.155 A SF158, FB4 L10, 11th-cent. context.

42. Bone.

75.25.156 A SF2099, F2518 L1. 13th-cent. context.

43-44. Points:

43. Bone (pig fibula).

75.25.158 A SF2112, L2 (2M, 104/996), unstratified.

44. Bone (pig fibula). Head broken, worn and rounded.

75.25.159 A SF3338, F2503 L2, 12th-cent. context.

1. E. Crowfoot in H. Clarke and A. Carter, Excavations in King's Lynn, 1963-1970, Society for Medieval Archaeology Monograph No.7 (1977), 311-12.
2. Cf. Ashmolean Museum 1967.451 (from Logic Lane).

BONE, IVORY AND ANTLER OBJECTS

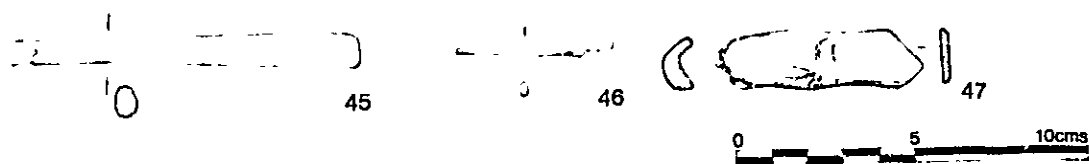

Fig.158

45. Bone, polished and shaped implement.
Broken along the shaft.
75.25.157 A GF3332, F79 L141, 15th-cent. context.
- 46-47. Crude Points:
46. Bone. Fragment only.
A SF163, L135, undated context.
47. Part of a long bone cut flat and given an angled point.
Surface worn very smooth.
A SF546, L2 (2M, 117/1000), unstratified.

BONE, IVORY AND ANTLER OBJECTS



Fig.159

48-49. Box Panels:

48. Trapezoid openwork panel with near-symmetrical acanthus motif and two rivet holes. The carving is, if finished, relatively crude. From a faceted lid, or a side panel. Ivory, possible walrus. I am grateful to Mr. J.G. Beckwith of the Victoria and Albert Museum for identifying the carving as late 11th- or early 12th-century in style. [1]

75.25.160 A SF4A, Trial Trench L15, undated context.

49. Rectangular panel, decorated with two rows of three circles and dot motifs, irregularly placed. There are four holes for iron rivets, also irregularly placed. Possibly from a cattle rib bone. [2]

75.25.161 A SF1165, F1540, 13th-cent. context.

1. Cf. J. Beckwith, Ivory Carvings in Early Medieval England, (1972), 131, No.64, and Pl. on p.72 for panels in the lid of an oval box of walrus ivory in the Victoria and Albert Museum. The box is of St. Alban's workmanship, c.1120, though the acanthus is the other way up within the trapezoid frames here.
2. Part of a casket with similar plaques on was found in York. D.M. Waterman, 'Late Saxon, Viking and Early Medieval Finds from York', Archaeologia, xcvi (1959), 86-87; Pl.XVII.

BONE, IVORY AND ANTLER OBJECTS

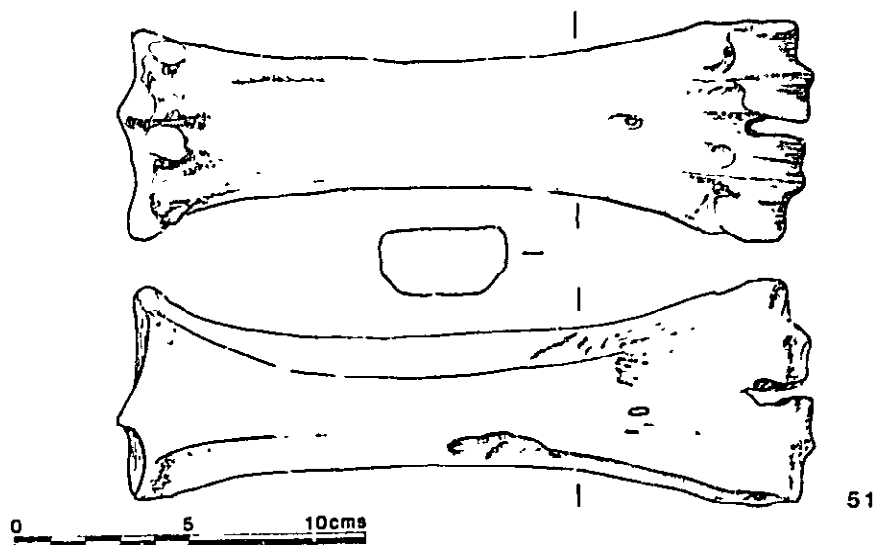

Fig.160

50-53. Skates:

50. Bone skate fragment. [1] The distal end of a horse metacarpus. Length 70mm. Not illustrated.
75.25.162 A SF3312, F133 L281, 11th-cent. context.
51. Bone skate. Metacarpel of a cow. Length 95mm.
75.25.163 A SF3316, F1503 L2, 11th-cent. context.

Cf. B. Durham, 'Archaeological Investigations in St. Aldates, Oxford', Oxoniensia, xlii (1977), 160-63, Fig.37, No.1.

BONE, IVORY AND ANTLER OBJECTS

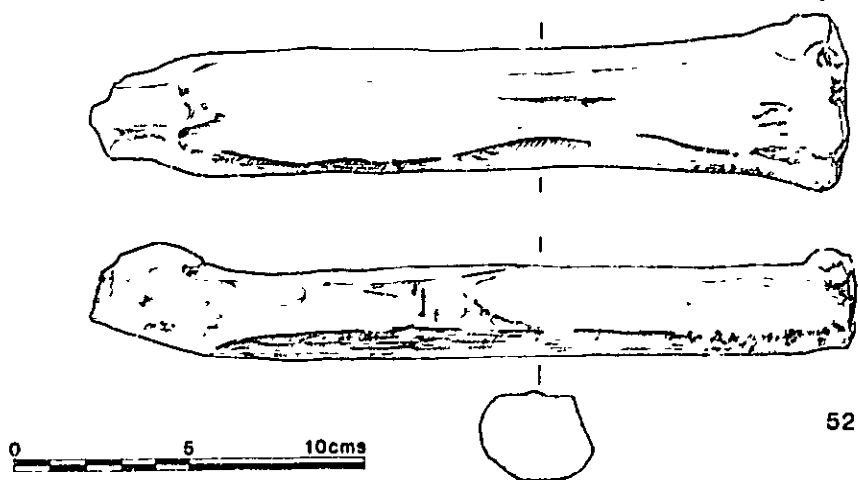

Fig.161

52. Horse bone skate roughout. Unused. Trimmed at the distal end, the shaft is also cut and shaped. Length 215mm.
75.25.164 A SF3336, F1538, 12th-cent. context.
53. Bone skate fragment (horse metapodial). Toe rounded by shaping and wear. Not illustrated.
75.25.165 A SF3337, F2501 L1, 13th-cent. context.

BONE, IVORY AND ANTLER OBJECTS

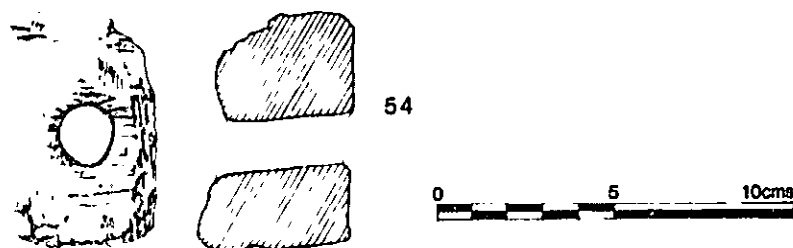

Fig.162

54 Length of red deer antler (identified by B. West), with transverse round hole. Crudely knife-trimmed to give irregular facetting at each end and around the edges of the hole. General abrasion has removed the sharpness of these cuts. The central area of cancellous material at each end has become concave from repeated striking, this being more marked at one end than at the other.

The object is a roughly-shaped hammerhead, one of a small number of recorded examples. [1] The precise date range and function of these antler tools have yet to be established. The use of this relatively soft but resilient material would be appropriate for working sheet metal for example.

The present example differs from the others of this general type in having no trace of the burr at the base of the antler. It could therefore have been cut from any point along the thick part of the beam.

75.25.166 A SF146, L2 (2M, 112/1000), unstratified.

1. A. MacGregor, Bone, Antler, Ivory and Horn, (Beckenham, 1985), 171-72. I am grateful to Mr. MacGregor for his comments on this type of hammerhead.

BONE, IVORY AND ANTLER OBJECTS

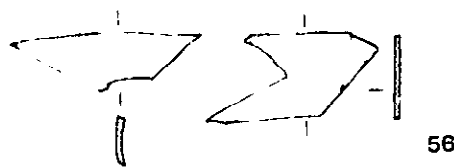
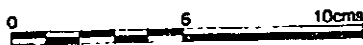

Fig.163

55-61. Miscellaneous:

55. Large animal rib worn to a rounded point at the end.
Not illustrated.

A SF3320, F501, 13th-cent. context.

56. Sheep and cattle rib fragments with cut edges and marks.
Possibly not worked. Cf. No.13.

A SF3335, F1527 L2, 12th-cent. context.

BONE, IVORY AND ANTLER OBJECTS

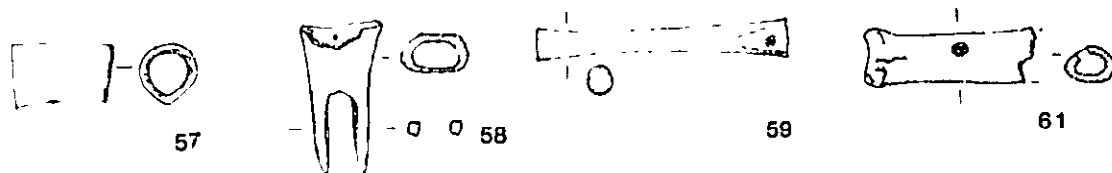

Fig. 164

57. Cut and highly polished bone tube with notches worn on the inside edges all around both ends.

75.25.167 A SF3319, F501, 13th-cent. context.

58. Sheep metacarpal (distal end) cut away to form two prongs. Polished on the outer sides of the prongs. [1]

75.25.168 A SF3322, F501 L1, 13th-cent. context.

59. Bone, possibly an immature sheep tibia. Cut, pierced and hollowed out at the proximal end. Cut at the distal end. Possibly an incomplete toggle or toy for spinning on twisted string. [2]

A SF3323, F501, 13th-cent. context.

60. Cattle (?) bone. Hollowed out at the distal end and the proximal end has been cut off. The shaft is polished by wear. The tip is broken. Not illustrated.

75.25.169 A SF3324, F512, 10th-cent. (or earlier) context.

61. Toggle? Pig metapodial. Pierced at the mid shaft on one side only, the proximal end is shaped, the distal end is broken.

75.25.170 A SF3339, F2520 L1, 12th-cent. context.

1. See A. MacGregor, Bone, Antler, Ivory and Horn, 1985, 192-93, for a discussion of this type of object, which may have been used to make plaited yarn. The term 'lucet' is suggested in place of 'thread-twister'; Cf. P.J. Huggins, 'The Excavation of an 11th-century Viking Hall and 14th-century Rooms at Waltham Abbey, Essex, 1969-71', Medieval Archaeology, xx (1976), 119, Fig.42, No.3.
2. Ibid., MacGregor, 102-103.

BONE, IVORY AND ANTLER OBJECTS

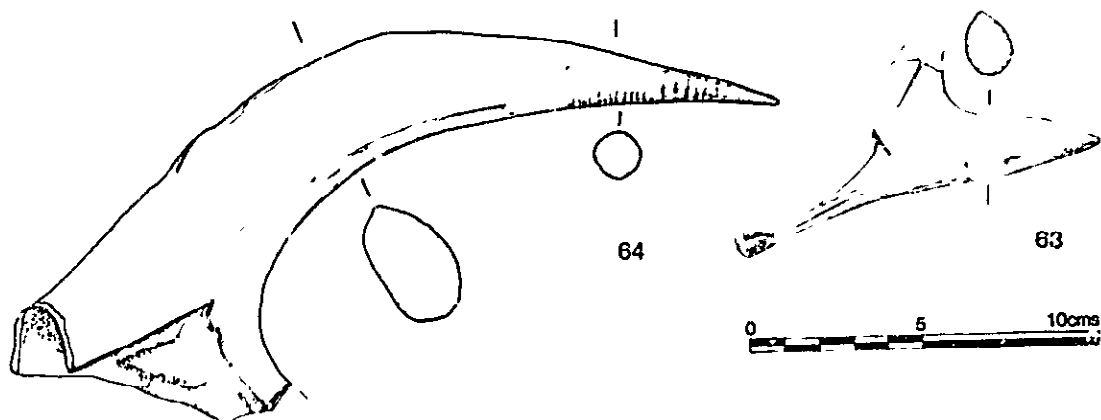

Fig.165

62-65. Worked Antler Fragments:

62. Off-cut from a roe deer antler. Length 77mm. Not illustrated.
A SF3313, F150 L327, 12th-cent. context.

63. Cut beam and tine fragment from a red or fallow deer.
A SF3314, F143 L313, 13th-cent. context.

64-65. Two sawn off beam and tine fragments from a red or fallow deer. The tine of one (No.64) is shaped with a rasp (?) leaving regular tool marks. Cut to a point for use as a borer. Length 20mm. No.65 is not illustrated.

A SF3315, F1014 L1090, 15th-cent. context.

BONE, IVORY AND ANTLER OBJECTS

The following objects have not been included in the catalogue:

A SF161, L135	Gnawed bone, not worked.
A SF517, F113 L192	Jaw bone with metal-coated teeth, lost.
A SF1005, L2 (2M, 110/1012)	Bobbin, lost.
A SF2126, F2522	Fragment, not identifiable.

BONE, IVORY AND ANTLER OBJECTS

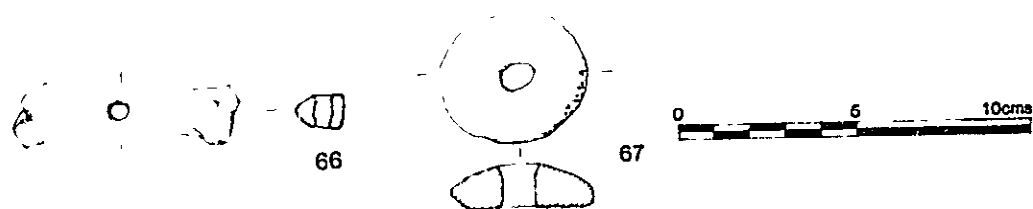

Fig.166

Site B, Greyfriars by Martin Henig.

66. Bone (phalange) pierced for use as a bobbin or toggle.
Length 62mm. Diameter of the perforation 5mm. [1]
75.27.19 B IV SF44, F66, 11th- to 12th-cent. context.
67. Bone spindlewhorl. Weight 10gm.
75.27.20 B VI SF48, F10, 11th- and 14th-cent. sherds from context.

1. Cf. M. Robinson, 'Excavations at Copt Hay, Tetsworth', Oxoniensia, xxxviii (1973), 106f; Fig.26, No.28.

BONE, IVORY AND ANTLER OBJECTS

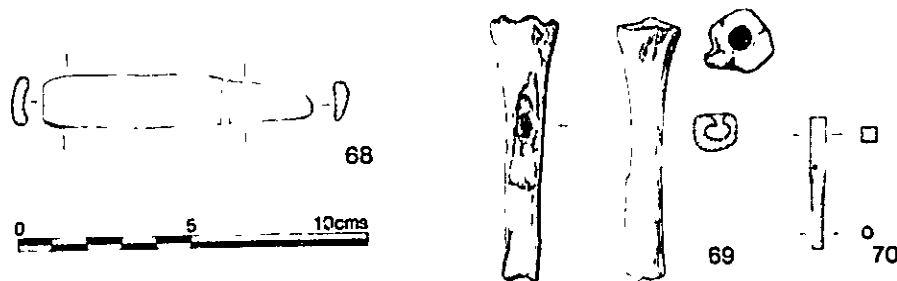

Fig.167

Site D, Littlegate by Martin Henig.

68. Two fragments of a bone implement. Pin beater?
75.33.5 D I SF23, F19, modern services.
69. Bone. Pierced throughout its length and with a hole along its side to facilitate its use as a whistle. [1] Length 71mm.
75.33.6 D I SF50, F53 L1, late 12th-cent. context.
70. Bone psaltery peg.
75.33.7 D II SF29, F59 L1, undated context.

1. Cf. M. Biddle, 'The Deserted Medieval Village of Seacourt, Berkshire', Oxoniensia, xxvi/xxvii (1961-62), 183-84; Fig.32, No.5; G.F. Bryant and J.H. Steane, Excavations at the Deserted Medieval Settlement at Lyveden. A Third Interim Report, Northamptonshire Museums and Art Gallery Journal, ix (1971), 69; Fig.19d.

M III 610

M III 611

M III 612

M III G13

LIST OF CONTENTS FICHE III

	Fiche
COPPER ALLOY OBJECTS (FIGS.92-113) by ALISON R. GOODALL; SPUR by BLANCHE ELLIS.	A3
LEAD AND LEAD ALLOY OBJECTS (FIGS.114-18) by GEOFF EGAN (NOS.1-24) AND ALISON R. GOODALL (NOS.25-28).	B13
IRON OBJECTS (FIGS.119-46) by IAN H. GOODALL; SPUR by BLANCHE ELLIS.	C6
SLAG FROM 31-34 CHURCH STREET by C.J. SALTER.	E8
BONE, IVORY AND ANTLER OBJECTS (FIGS.147-67) by GEOFF EGAN (NOS.1-65) AND MARTIN HENIG (NOS.66-70); MATERIAL IDENTIFICATION by PHILIP ARMITAGE AND BOB WILSON.	F1

Photocopies of the microfiche can be obtained from the
Oxford Archaeological Unit, 46 Hythe Bridge Street, Oxford, OX1 2EP.